



# *epic*<sup>TM</sup>X

User Manual

## Delight Your Patients, **Faster.**



# Table of Contents

Table of Contents .....	1
Introduction .....	4
1. Packaging .....	5
1.1 System Parts List.....	5
1.2 Facility Requirements .....	5
2. Equipment Description .....	6
2.1 General .....	6
2.2 Base Console .....	6
2.3 Control Panel.....	6
2.4 Surgical Delivery System.....	6
2.5 Fiber Optic Connection .....	7
2.6 Single-Use Tips .....	8
2.7 Surgical Handpiece Assembly .....	9
2.8 Whitening/Contour Handpiece (Optional Accessory) .....	10
2.9 Deep Tissue Handpiece (Optional Accessory).....	11
3. Safety .....	12
3.1 Precautions .....	12
3.2 Safety Instructions .....	12
3.3 Safety Features .....	13
Energy Monitor .....	13
System Monitor .....	13
Power Switch .....	13
Access Key Code.....	14
Control Button.....	14
Wireless Footswitch .....	14
Remote Interlock.....	14
Emergency Stop .....	15
Functional Display.....	15
3.4 Safety Classification .....	15
4. Operating Instructions.....	16
4.1 System setup.....	16

4.2 Operation - Turn on the <i>EPIC X</i> .....	17
4.3 Settings Screen .....	17
4.4 Pairing the Footswitch to the Laser console.....	18
4.5 Control Button .....	19
4.6 Entering READY or STANDBY Modes .....	19
4.7 READY Mode .....	19
4.8 Wireless Footswitch.....	20
4.9 Peak Power Display .....	20
4.10 Pulse Mode Selection .....	20
4.11 Using the <i>EPIC X</i> Touch Screen Display .....	22
4.12 Procedures Button .....	23
4.13 Turn the Laser Console Off.....	23
5. Specifications .....	24
5.1 General .....	24
5.2 Electrical.....	24
5.3 Laser .....	24
5.4 Other Light Sources.....	25
6. Contraindications, Warnings & Precautions .....	26
6.1 Contraindications.....	26
6.2 Warnings and Precautions.....	26
Prescription Statement.....	26
Eyewear.....	26
Anesthesia.....	26
Adjacent Structures.....	26
Suction.....	26
Plume Removal.....	27
Clinical Use .....	27
Training.....	27
7. Clinical Applications.....	28
7.1 Introduction.....	28
7.2 Indications for Use.....	28
7.3 Soft Tissue Surgery and Other Dental Use .....	29
Tip Initiation: Parameters and Method (Not required if using pre-initiated tips).....	29

Pre-programmed Settings for Dental Procedures.....	30
7.4 Table of Pre-Programmed Settings.....	31
7.5 Teeth Whitening Procedure .....	32
7.6 Pain Therapy .....	32
Pain Therapy – Adverse Effects.....	33
Pain Therapy – Warnings and Precautions .....	33
Recommended Use .....	34
Using the Deep Tissue Handpiece.....	34
8. Maintenance .....	35
8.1 Daily Maintenance .....	35
8.2 Cleaning and Sterilization Procedures .....	35
Cleaning and Disinfecting Instructions-Surgical Handpiece, Reusable Fiber Optic Cable ..	35
Manual Cleaning of the Surgical Handpiece:.....	35
Steam Sterilization for Surgical Handpiece, Single Use Tips.....	36
Disinfecting the Whitening/Contour Handpiece .....	37
Disinfecting the Deep Tissue Handpiece.....	37
8.3 Installing/Replacing the Console Battery Pack.....	37
8.4 Changing the Wireless Footswitch Batteries.....	38
8.5 Transportation .....	38
8.6 Storage.....	38
9. Calibration.....	39
10. Software Specification .....	39
11. Troubleshooting .....	39
Appendix A – Tip Guide and Accessories.....	41
Appendix B – Labeling .....	42
Appendix C – Safety Precautions for Lithium-Ion Battery Packs.....	44
Appendix D – Electromagnetic Compatibility .....	46
Appendix E – Wireless Equipment Compliance Statement.....	50

## Introduction

The *EPIC™ X* diode laser system is a surgical and therapeutic device at the cutting edge of technology, designed for a wide variety of oral soft tissue procedures and dental whitening, as well as for use in providing temporary relief of minor pain.

The *EPIC X* utilizes a solid state diode as a semiconductor source for invisible infrared radiation. The energy is delivered to the treatment site via a flexible fiber connected at one end to the laser source and the other end to the Handpiece. Various types of single use, disposable tips are designed and optimized for different applications. The device is activated by means of a wireless footswitch.

This is a prescription device that is indicated for professional use only by licensed medical and dental practitioners. The use of this device requires proper clinical and technical training. This manual provides instructions for those professionals that have completed the appropriate training.

When used and maintained properly, the *EPIC X* will prove a valuable addition to your practice. Please contact BIOLASE Customer Service at 1-800-321-6717 in the U.S. for any service needs. If you are located outside the USA, please contact your BIOLASE-authorized distributor.



# 1. Packaging

## 1.1 SYSTEM PARTS LIST

The *EPIC X* laser system includes the following:

1. Laser console (lithium ion battery pack already installed)
2. Screen protectors box (Peel-off clear screen cover - qty. 30)
3. Delivery System (Fiber Optic Assembly installed)
4. Assorted Surgical tips
5. Surgical Handpiece box (2-pack)
6. Three (3) pairs of protective laser eyewear
7. DC power supply and power cord (one (1) US and one (1) International)
8. Welcome Kit (Welcome Letter, User Manual , BIOLASE store information, Quick Setup Guide, Guide to Online Training & Product Registration Card, Limited Warranty Information)
9. Laser warning sign
10. Tip initiation kit
11. Remote Interlock cable
12. Philips-head screwdriver (for installing Footswitch batteries)
13. Footswitch
14. AAA batteries (2)

**NOTE:** The laser ships with the lithium ion battery pack already installed.

**NOTE:** Use proper care when transporting the unit. Refer to Section 8 in this User Manual for instructions.

**WARNING:** No modification of this equipment is allowed.

## 1.2 FACILITY REQUIREMENTS

- Electrical Supply (100-240V ~): 1.5A, 50/60Hz
- Environmental Requirements: Temperature: 20-25 °C  
Humidity: 15-95%, Non-condensing

## 2. Equipment Description

### 2.1 GENERAL

The *EPIC X* system consists of three components:

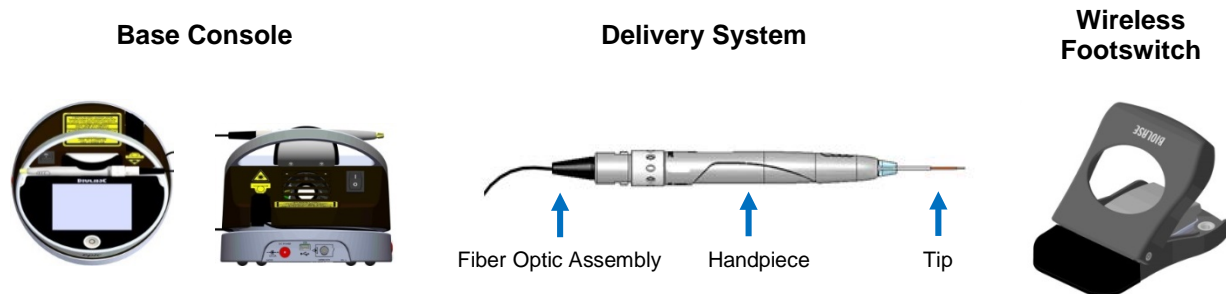

### 2.2 BASE CONSOLE

The Console has a Display Panel (Touch Screen and Control Button) in front. It can be powered by an external mains power supply or an internal replaceable lithium ion battery pack, 14.4V, 2.9 Ah.

### 2.3 CONTROL PANEL

Item	Item Description
CONTROL Button	Activates the controls and display; places the unit into STANDBY or READY or SLEEP mode.
LED Indicator	<p><b>Amber</b> indicates unit is in STANDBY mode.</p> <p><b>Green</b> indicates unit is in READY mode.</p> <p>Blinking <b>green</b> indicates the emission of laser power.</p> <p>Blinking <b>blue</b> indicates pairing between the footswitch and laser console is active</p>

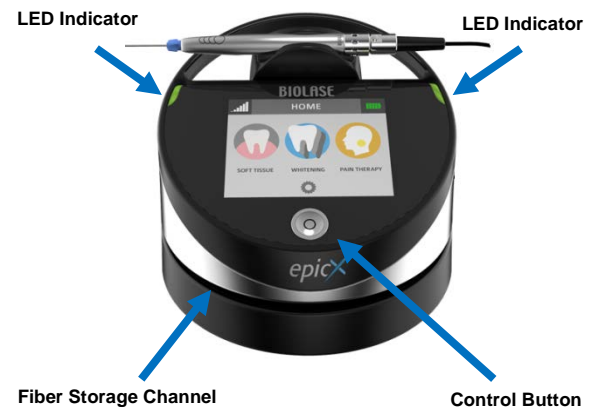

Figure 2.1: Control Panel (Front View)

### 2.4 SURGICAL DELIVERY SYSTEM

**NOTE:** All fiber optic cables, Handpieces & tips are shipped non-sterile.

The *EPIC X* Delivery System with surgical Handpiece consists of:

- Re-useable Fiber Optic Assembly (Figure 2.8)
- Re-useable Surgical Handpiece (Figure 2.9)
- Disposable Tips (Appendix A)



**NOTE:**

The fiber optic cable is detachable from the console. The Handpiece is a re-usable accessory and will require cleaning and sterilization prior to each patient treatment. Tips are intended for single-use only and must be disposed of after each patient use. Proper tip disposal in a biohazard medical waste Sharps container is required. Tips must be steam sterilized prior to use. For instructions on cleaning and sterilization of the Handpiece and tips refer to Section 8.

## 2.5 FIBER OPTIC CONNECTION

The EPIC X ships with the fiber optic cable already attached.

**CAUTION:**

Do not connect or disconnect the fiber while the laser console is turned on. Only connect or disconnect the fiber when the laser console is turned off.

To disconnect the fiber optic cable from the laser console, **make sure the laser console is turned off and the cable is completely unwound from the console base**, grab the fiber optic access plug and slowly pull it straight back from the optical access port (Figure 2.3).

To re-install the fiber optic cable, **make sure the laser console is turned off**. The fiber optic cable is attached to the console by inserting the optical access plug (Figure 2.2) into the optical access port (Figure 2.3).

**NOTE:**

Make sure you hear the fiber optic “click” into place; if you do not hear it “click,” remove the fiber optic and reinstall it.

For storage, wind the cable in the fiber storage channel around the base of the console in a counterclockwise direction (Figure 2.1).

**CAUTION:**

Do not bend the fiber optic at a sharp angle, as it can break. Make sure it is not caught or pinched between the housing and the fiber optic access plug.

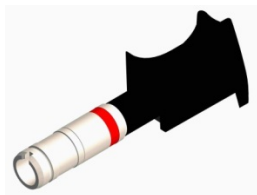

Figure 2.2: Fiber Optic Access Plug



Figure 2.3: Optical Access Port



## 2.6 SINGLE-USE TIPS

The tips are single-use accessories and are provided in three core diameters: 200µm, 300µm, and 400µm, in different lengths (see Appendix A).

**CAUTION:** Tips are single-use only to avoid cross-contamination and are designed to withstand only a single sterilization cycle; they must be disposed of after use in a biohazard medical waste Sharps container. Always visually inspect the tip prior to use to make sure it is free of debris or damage.

**CAUTION:** Be aware that the metal/plastic cannula on the tips may become hot during use. Avoid contact of the cannula with any tissue.

To connect the tip, **first connect the Handpiece to the fiber**, then insert the tip firmly into the distal end of the Handpiece as far as it will go and tighten by turning clockwise (Figure 2.4). Bend the metal cannula according to the specific procedure requirements (Figure 2.7).

Remove the fiber tip by twisting the tip counterclockwise (Figure 2.5).

**NOTE:** To provide proper laser operation, **do not** connect tips when the handpiece is disconnected from the fiber.

Tip Assembly



Figure 2.4: Insert the fiber tip into the Handpiece (**only when the Handpiece is connected to the fiber**) and twist **clockwise** until snug

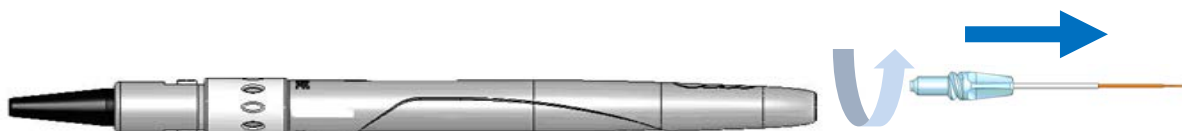

Figure 2.5: Remove the fiber Tip by twisting the tip **counterclockwise**

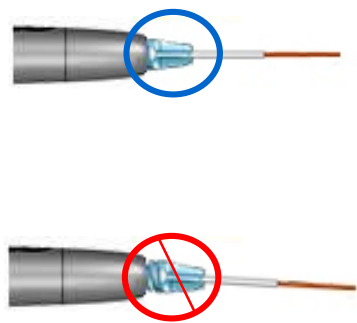

Figure 2.6: When installing the tip, make sure it is seated properly (thread correctly)

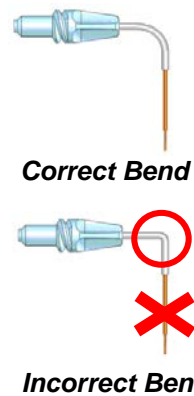



Figure 2.7: Bending the tip cannula

**WARNING:**

When the aiming beam is not present or has a significantly asymmetrical shape:

- ▶ For tips that require initiation: change the tip
- ▶ For tips that do not require initiation: change the tip; press  to bypass initiation requirement.

## 2.7 SURGICAL HANDPIECE ASSEMBLY

- ▶ Connect the Handpiece to the fiber optic assembly by pushing the Handpiece onto the fiber shaft until it clicks on and is secured.

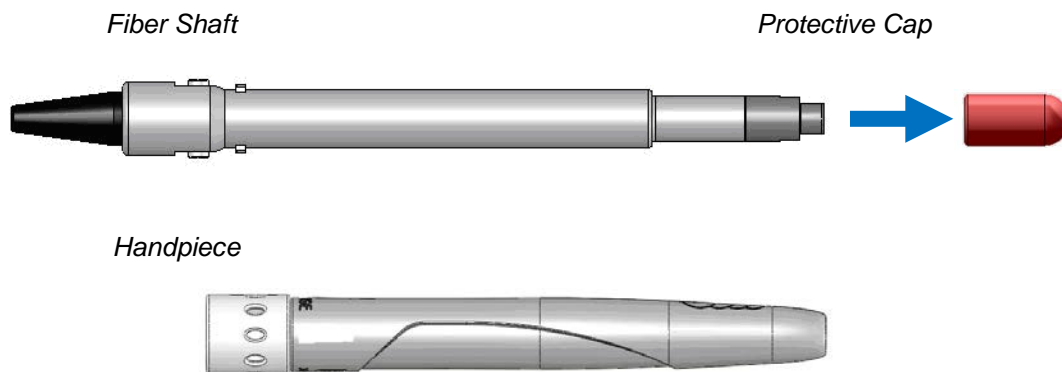

Figure 2.8: Connecting the Handpiece to the fiber optic assembly



Figure 2.9: Surgical Handpiece Assembly fully assembled

- ▶ Disconnect the Handpiece from the fiber optic assembly (Figure 2.10) by
  1. Taking the Handpiece body in one hand and the shaft in the other,
  2. Pushing the two buttons on the Fiber Shaft,
  3. Pulling the Handpiece with the ring to separate.

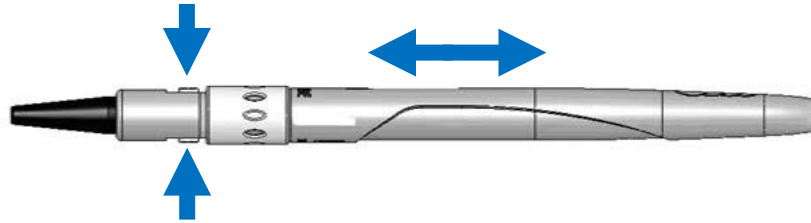

Figure 2.10: Disconnect the Handpiece from the fiber optic assembly by pressing both buttons at the base of the Fiber Shaft

## 2.8 WHITENING/CONTOUR HANDPIECE (OPTIONAL ACCESSORY)

**NOTE:**

The Whitening/Contour Handpiece is reusable and equipped with a disposable non-sterile protective shield for single patient use. The Handpiece is non-sterile and requires disinfection before and after each patient treatment. **This Handpiece cannot be sterilized in the autoclave.** For disinfection instructions refer to Section 8.

Always wipe the disposable shield with alcohol prior to use. The disposable shield is for single-use only to avoid cross-contamination. Dispose of when the treatment session is completed.



Figure 2.11: Whitening/Contour Handpiece



Figure 2.12: Disposable Non-Sterile Shield

The area of Laser Energy Output for the Whitening/Contour Handpiece is 35mm x 8mm = 2.8cm<sup>2</sup> Spot Size.

To connect the Handpiece to the fiber optic cable, push the Handpiece onto the fiber shaft until it clicks on and is secured.

To disconnect the Handpiece from the fiber optic assembly:

- Take the Handpiece body in one hand and the shaft in another.
- Press both buttons at the base of the Fiber Shaft.
- Pull the Handpiece from the ring to separate.

## 2.9 DEEP TISSUE HANDPIECE (OPTIONAL ACCESSORY)

### NOTE:

The Deep Tissue Handpiece is reusable and equipped with a disposable non-sterile protective shield for single patient use. The Handpiece is non-sterile and requires disinfection before and after each patient treatment. **This Handpiece cannot be sterilized in the autoclave.** For instructions on disinfecting the Handpiece, refer to section 8.

Always wipe the disposable shield with alcohol prior to use. The disposable shield is for single-use only to avoid cross-contamination. Dispose of when the treatment session is completed.

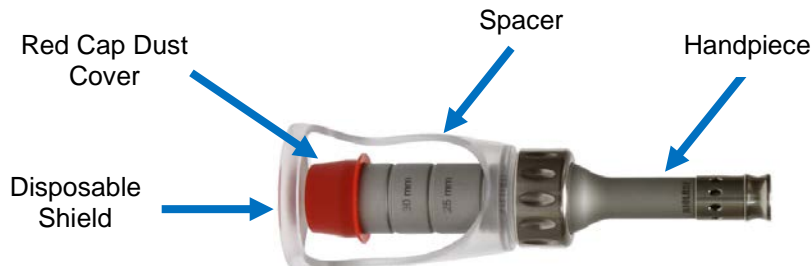

Figure 2.13: Deep Tissue Handpiece

Remove Red Cap Dust Cover from the Deep Tissue Handpiece.

Slide Handpiece over shaft until it clicks into place (Figure 2.14).



Figure 2.14

Place protective shield over the adjustable spacer (Figure 2.15).



Figure 2.15

Loosen the Lock Ring and set the Spacer at the desired spot size detent location (Figure 2.16). Tighten the Lock Ring.



Figure 2.16

The Handpiece is now ready to use.

To remove the Handpiece, press and hold both buttons at the base of the Fiber Shaft and pull the Handpiece away from the shaft.

## 3. Safety

### 3.1 PRECAUTIONS

Failure to comply with precautions and warnings described in this User Manual may lead to exposure to dangerous optical radiation sources. Please comply with all safety instructions and warnings.

### 3.2 SAFETY INSTRUCTIONS

Follow these safety instructions before and during treatments:

- When the laser is in use, all operatory entrances must be marked with an appropriate warning sign

(one (1) included). 

- Do not operate in the presence of explosive or flammable materials. Flammable anesthetics or oxidizing gases such as nitrous oxide (N<sub>2</sub>O) and oxygen (O<sub>2</sub>) should be avoided. Solvents of adhesives and flammable solutions used for cleaning and disinfecting should be allowed to evaporate before laser is used. Attention should also be drawn to the danger of ignition of endogenous gases.

**All persons present in the operatory must wear protective laser eyewear.**

**NOTE:** For replacement or additional protective laser eyewear, please contact BIOLASE.

**CAUTION:** Periodically inspect laser eyewear for pitting and cracking.



**LASER WARNING:** Use of controls or adjustments or performance of procedures other than those specified herein may result in hazardous radiation exposure.

**WARNING:** Do not use this unit if you suspect it of functioning improperly or other than described herein.

**CAUTION:** This unit has been designed and tested to meet the requirements of electromagnetic, electrostatic, and radio frequency interference standards. However, the possibility of electromagnetic or other interference may still exist. Relocating the device may help to eliminate the interference.

**CAUTION:** Always ensure that the proper laser parameters are set before the *EPIC X* laser is used in a clinical setting.



**LASER WARNING:** Always ensure that the protective laser eyewear is appropriate for the laser wavelength.

- Do not look directly into the beam or at specular reflections.
- Never direct or point the beam at a person's eyes.
- Always place the system into STANDBY mode (by pressing the Control Button while in READY mode) before exchanging Handpieces or disposable tips.
- Toggle the ON/OFF switch (located on the rear of the console) to the OFF (O) position before leaving the unit unattended.



**LASER WARNING:**

Do not open console housing at any time. Danger from optical radiation may exist.



**LASER WARNING:**

Do not aim the laser at metallic or reflective surfaces, such as surgical instruments or dental mirrors. If aimed directly at these surfaces the laser beam will reflect and create a potential hazard.

**CAUTION:**

Be aware that the metal / plastic cannula on the tips may become hot during use. Avoid contact of the cannula with any tissue.

### 3.3 SAFETY FEATURES

#### *Energy Monitor*

The energy monitor measures and verifies power output. Power deviations of more than  $\pm 20\%$  from the selected value will cause the display to show the error message: "LASER CURRENT HIGH/LOW".

The laser console will not operate until the system first clears the error and then goes into READY mode. If the error message persists, please contact BIOLASE Service at 1-800-321-6717.

#### *System Monitor*

The system monitors the emergency stop switch, remote key, wireless footswitch connection, and output power. An error in any one of these will stop the system. The text display will indicate the type of error. Operation cannot resume until the error is cleared.

#### *Power Switch*

The laser console can be switched ON (I) or OFF (O) using the Power Switch on the back of the console.

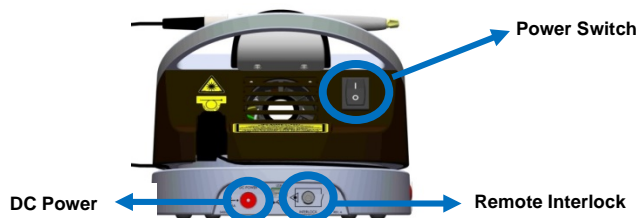

Figure 3.1: Power Switch, DC Power Input, Remote Interlock



Figure 3.2: Power Supply Module with cord

**CAUTION:**

Use only the Power Supply Module supplied with the *EPIC X* laser system (BIOLASE Part Number 2400129).

### Access Key Code

The Access Key Code prevents unauthorized use of the system. It is activated every time the system is turned on with the Power Switch (refer to Section 4 for the necessary code).

**NOTE:**

Placing the laser in sleep mode by pressing and holding the Control button on the front panel does not re-set the Access Key Code. Turn the Power Switch OFF (O) only when the system will not be in use for a long period of time.

### Control Button

Once the power switch is set to the ON (I) position, enter the access key code. After setting the desired parameters for a procedure, press the CONTROL button on the control panel to enter into READY mode. The aiming beam will illuminate to indicate that the system is ready for use.

### Wireless Footswitch

The *EPIC X* will not emit laser energy until the user presses down on the Footswitch while the laser is in READY mode. The footswitch is designed to work using wireless technology.

Two (2) AAA batteries are required to power the footswitch (included). (For instructions on how to replace the footswitch batteries, see Section 4.)

The footswitch is protected by a metal cover. To access, first press down on the cover to unlatch it. Now the footswitch can be pressed to fire the laser

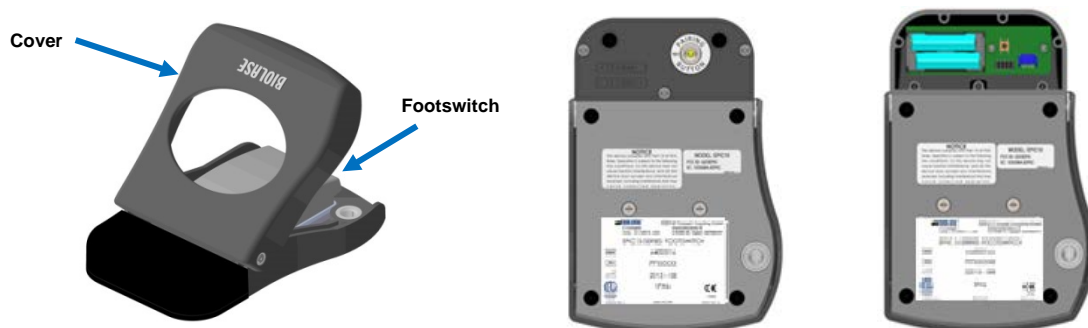

Figure 3.3: Footswitch

### Remote Interlock

This feature allows the laser to be connected to a remote sensor which prevents it from firing when the sensor is triggered. To install the Remote Interlock, insert the plug (a) at the end of the connector into the rear of the laser console (Figure 3.1) and attach the two wires (b) at the other end to a door switch; the laser will stop immediately when the connection to the door switch is deactivated, *i.e.*, when the door is opened.



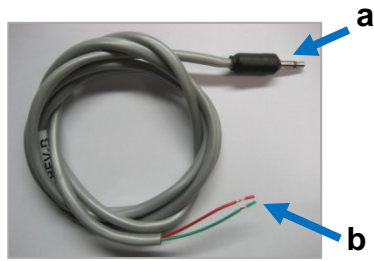

Figure 3.4: Remote Interlock Connector

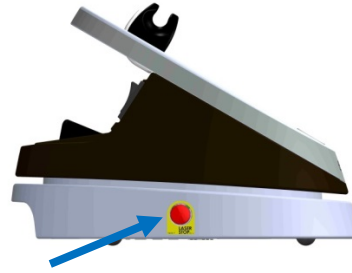

Figure 3.5: Emergency Laser Stop (Left Profile View)

### *Emergency Stop*

Press the red Emergency Laser Stop button (Figure 3.5) to instantly turn off the laser console. The error screen will display an “Emergency Switch Error” message and the amber LED will begin flashing. To clear the error, press the Emergency Laser Stop button again; in 2 to 5 seconds the amber LED will stop flashing and the system will automatically go into STANDBY mode.

### *Functional Display*

The System Color Display with Touch Screen and LED indicators on the control panel show the functional conditions of the system.

## **3.4 SAFETY CLASSIFICATION**

The following safety classifications are applicable to the device:

- Laser Radiation – Class 4
- Aiming Beam – Class 2
- Type of protections against electrical shock – Class 2
- Degree of protection against electrical shock – Type B Applied Part
- Not protected against water ingress – Ordinary Equipment
- Not suitable for use in presence of flammable anesthetic mixture
- Operation Mode – Continuous Wave and Pulse Mode
- Wireless Footswitch – IPX6

## 4. Operating Instructions

### 4.1 SYSTEM SETUP

- Place the unit in a clean, dry, and well-ventilated area.
- Verify power switch is in the OFF (O) position.
- *EPIC X* will work using either DC power or the rechargeable battery pack:
  - *DC Power*: Connect the power cord of the power supply to the laser console and plug into a wall outlet
  - *Rechargeable Battery*: The *EPIC X* is shipped with the battery pack already installed; to charge the battery pack, connect the power cord of the DC power supply to the laser console and plug into a wall outlet. Before first use, fully charge the battery (at least 3 hours). Once the battery is charged, unplug the power cord from the wall outlet and the laser console. The laser console will run on battery power alone.

**NOTE:**

To fully charge the battery, plug the power supply in and then turn the laser console ON (I) at the Power Switch. The laser console will start to charge and the unit will go into sleep mode (with the screen off) after 5 minutes; if the power supply is plugged in but turned OFF (O) at the Power Switch, the battery will still charge, but at a slower rate.

**CAUTION:**

Do not connect or disconnect the fiber while the laser console is turned on. Only connect or disconnect the fiber when the laser console is turned off.

**CAUTION:**

Do not cover or block ventilation channels. These channels provide an air-flow path to cool the unit.

**CAUTION:**

Do not bend the fiber optic at a sharp angle, as it is can break. Make sure it is not caught or pinched between the housing and the fiber optic access plug.

- Remove protective cap from the end of the fiber shaft (see Figure 2.8).
- Carefully connect the Handpiece to the fiber optic assembly (see Figure 2.9).
- Insert the selected tip and tighten it clockwise until snug (see Figure 2.4).
- Wind any excess fiber optic cable onto the fiber spool counterclockwise around the base of the console (see Figure 2.1).



- The Handpiece is now ready to use. To store the Handpiece, place it in the Handpiece holder located at the top of the laser console.



**LASER  
WARNING:**

Never point the laser at a person's eyes.



**LASER WARNING:**

Never operate the laser without a fiber tip attached.



**LASER WARNING:**

All persons present in the operatory must wear protective eyewear when the laser is in use.

## 4.2 OPERATION - TURN ON THE EPIC X

Ensure that the battery has enough charge for operation, or connect the power supply cord to the power connector on the laser console and plug the cord into a wall outlet.

Turn the Power Switch at the rear of the console to the ON (I) position. The “BIOLASE” logo screen will appear (Figure 4.1). After three (3) seconds the *EPIC X* “Welcome” screen will be displayed (Figure 4.2).



Figure 4.1

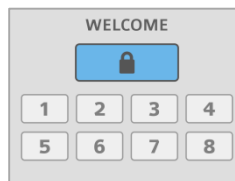

Figure 4.2



Figure 4.3

- Enter the three digit access code using the touch screen. The Access Key Code is **888**. (If the incorrect code is entered, an 'X' appears briefly in the window (Figure 4.3); press the 'X' or wait 3 seconds to revert back to the Welcome screen; re-enter the correct code.
- The system will go to the HOME screen which identifies three procedure categories to choose from: Soft Tissue, Whitening, Pain Therapy.

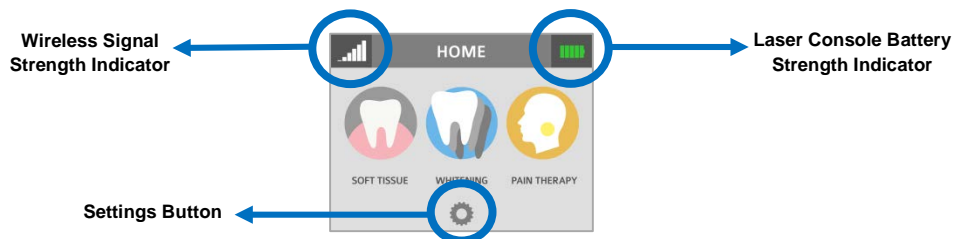



Figure 4.4: Home Screen

## 4.3 SETTINGS SCREEN

Pressing the Settings button  on the HOME screen accesses the Settings screen; this screen allows the user to make changes to several system settings:

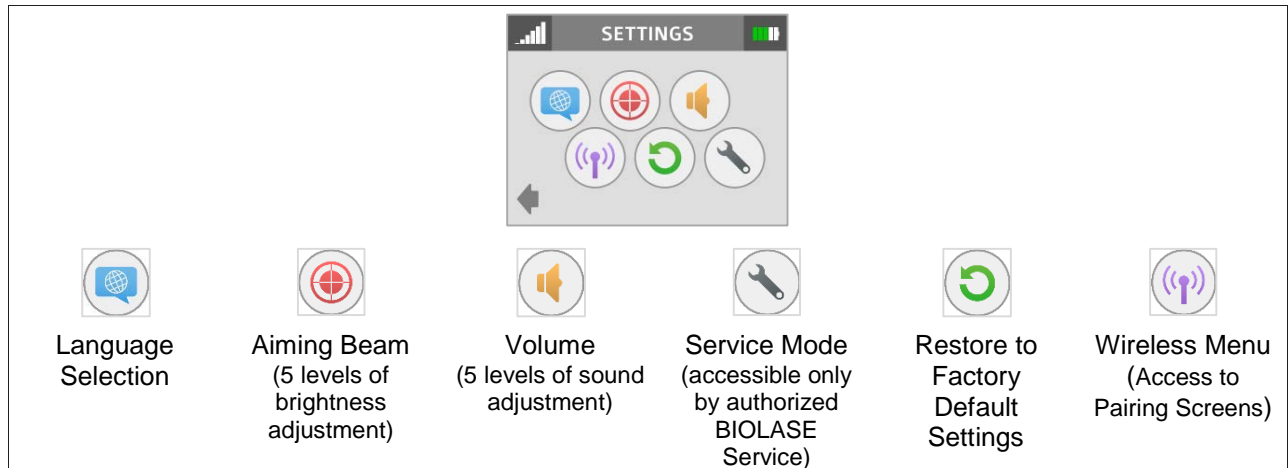



Figure 4.5

#### 4.4 PAIRING THE FOOTSWITCH TO THE LASER[JB1] CONSOLE

Verify that the footswitch and laser console are paired; a blue LED indicator light on the laser console will blink when pairing is established. The laser and footswitch are shipped already paired. However, if pairing is not confirmed, an  will appear in the pairing icon located in the upper left hand corner of the touchscreen (Figure 4.6).

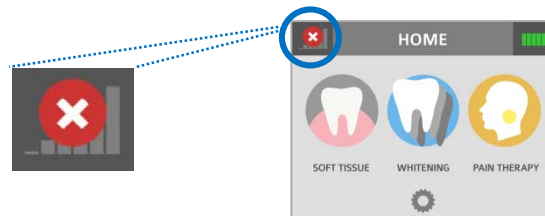



Figure 4.6

To re-establish pairing, take the following steps:

1. Go to the Settings menu on the laser console display by pressing the Settings button ; select the "Wireless" icon. 

2. A screen will appear indicating that pairing of the footswitch to the laser console has been lost (Figure 4.7); press the green PAIR button. 



Figure 4.7

3. The message that "PAIRING WILL NOW BEGIN" will appear (Figure 4.8); press the green check mark to continue. 



Figure 4.8

4. To complete the pairing process, turn the footswitch over and press the Pairing Button  for four (4) seconds (Figure 4.9).



Figure 4.9

- 5a. The Wireless screen will appear indicating that pairing was successful and that the footswitch and laser console are now paired (Figure 4.10). Proceed to step 6.



Figure 4.10

- 5b. If pairing has not occurred, the Wireless screen will appear again indicating that pairing was not successful (Figure 4.11); press the green button to repeat steps 3 and 4. 



Figure 4.11

6. Press the Settings button to return to the Settings menu; press the arrow on the bottom left of the Settings screen to return to the Home screen (Figure 4.12).

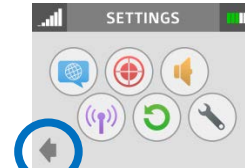

Figure 4.12

## 4.5 CONTROL BUTTON

The CONTROL button on the front of the laser console (Figure 2.1) is a multi-functional button. Pressing and holding the Control Button for approximately two (2) seconds will allow the transition from STANDBY or READY mode to SLEEP mode. Note that you will not be allowed to go into READY mode unless you have chosen a treatment module on the HOME screen first.

## 4.6 ENTERING READY OR STANDBY MODES

Press and release the Control Button to place the laser console into either READY or STANDBY mode. The laser console will only emit laser energy when the footswitch is pressed and the laser console is set to READY mode. While in READY or STANDBY mode, mode setting and/or power setting values may be changed only when the laser is not firing. If the laser is firing (*i.e.*, the footswitch is engaged), the ability to change the settings is blocked. ("READY" or "STANDBY" is displayed in the lower right hand corner of the display screen).

## 4.7 READY MODE

When entering READY mode, the laser console fan will turn on and pressing the footswitch will activate laser radiation. There is a two (2) sec delay between switching to READY mode and the ability of the laser console to emit a laser beam.

**NOTE:**

The aiming beam is on only when the laser is in READY mode or when adjusting the brightness of the beam while in Settings mode. If the aiming beam is not visible in either instance, remove the Handpiece and confirm the beam is actually on by shining the end of the trunk fiber on a plain, non-reflective surface. **DO NOT** look directly at the output end of the trunk fiber. If the aiming beam is not on, turn off the laser console, then remove and re-install the trunk fiber (see Section 2.6). If the aiming beam is still not on, turn off the laser console and call Biolase Service.

#### **4.8 WIRELESS FOOTSWITCH**

The wireless footswitch is powered by two (2) AAA batteries.

When the wireless footswitch is pressed in READY mode and the laser fires, a beeping sound indicates that laser energy is present. A green LED will begin flashing and a blue LED will light at the top corners of the laser console, confirming the footswitch and laser are paired.

In the top left corner of most screens is a Signal Strength Indicator  which displays the signal strength between the laser console and the footswitch (strongest is five (5) bars). Pressing and releasing the footswitch while in Standby mode will update this indicator. Although the unit will work with a signal level as low as one (1) bar, a weaker signal level will make the connection between the footswitch and laser console more vulnerable to wireless (RF) interference from other sources, such as cell phones or microwaves. To improve the signal strength, reposition either the footswitch or the laser console until the signal indicator achieves the strongest possible level for optimal operation.

**NOTE:**

When the footswitch is not in use, it will go into SLEEP mode to conserve battery power. It automatically reactivates when it is pressed.

#### **4.9 PEAK POWER DISPLAY**

This number is shown only when the system is in pulse mode and presents the value of the peak power based on the Power Setting and Pulse Mode.

#### **4.10 PULSE MODE SELECTION**

Pulse Mode selection graphically indicates whether the system is in Continuous Mode or in Pulse Mode.

In Continuous Mode, laser power is constantly delivered when the laser console is in Ready Mode and the wireless footswitch is activated.

In Pulse Mode, laser power is delivered in repetitive pulses, controlled by the Pulse Length and Pulse Interval settings.

Pressing the Pulse Mode button will allow switching between Pulsed and Continuous Modes (Figure 4.14).

Mode*	Pulse Duration (on)	Pulse Interval (off)	Duty Cycle (Time On/Time off)
CP0	10 microseconds	40 microseconds	20%
CP1	100 microseconds	200 microseconds	33%
CP2	1 millisecond	1 millisecond	50%
P3	20 milliseconds	20 milliseconds	50%

\*CP = Comfort Pulse; P3 = Pulsed Mode which is the standard for most diode lasers currently available to the dental market

Figure 4.13

**NOTE:** Operating the laser at a shorter pulse duration typically results in lower tissue temperature.

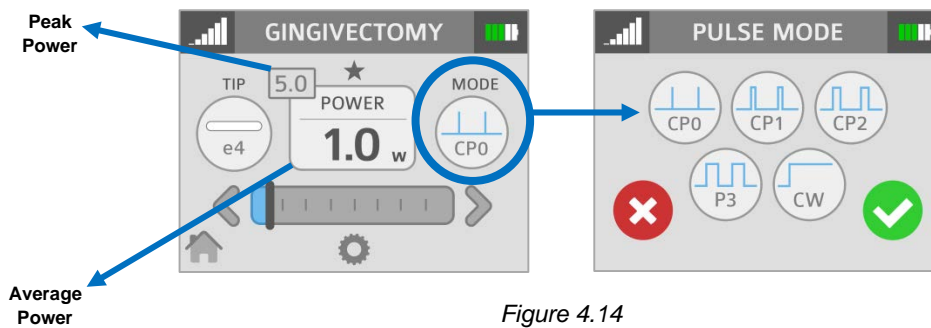

Figure 4.14



#### 4.11 USING THE EPIC X TOUCH SCREEN DISPLAY

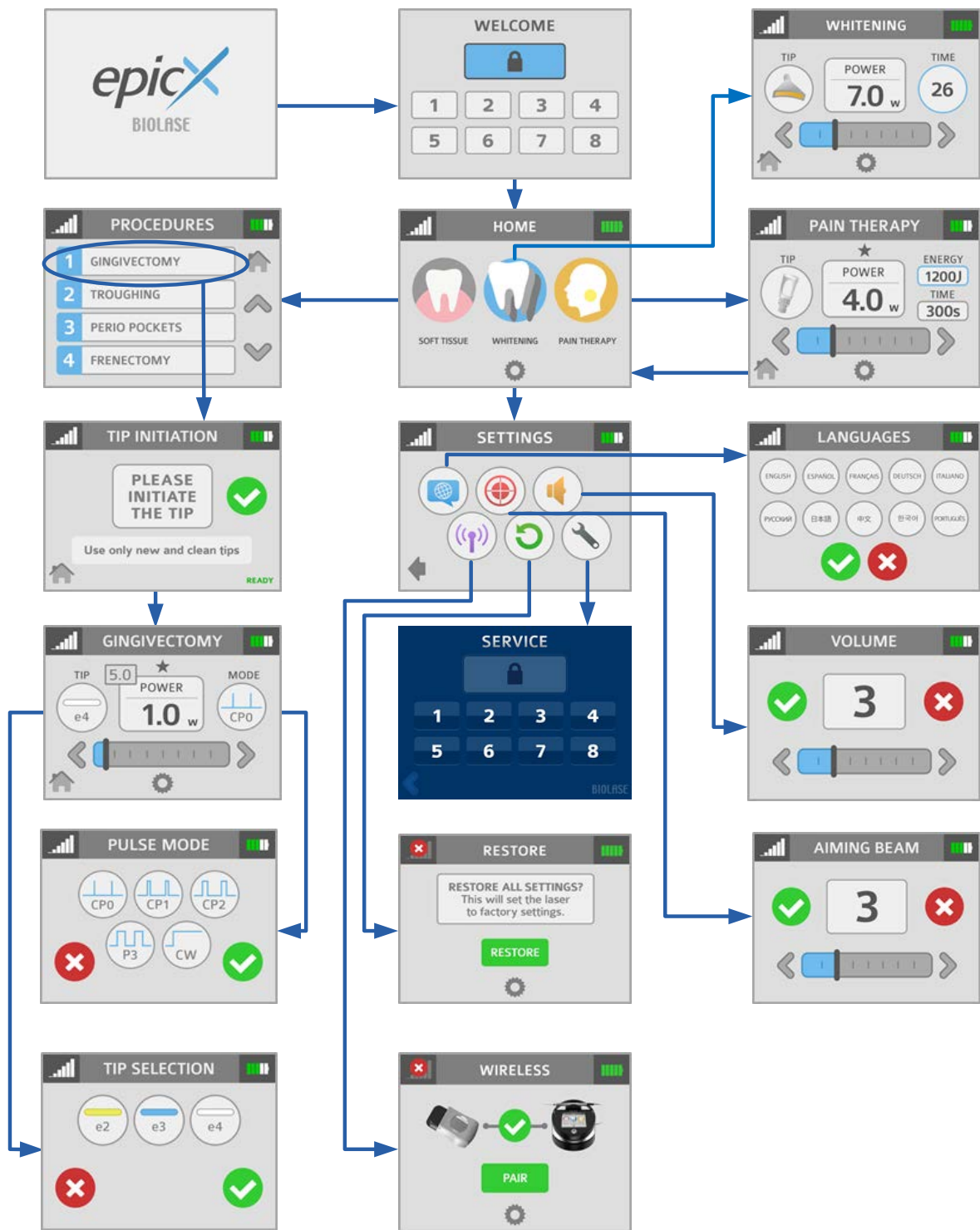

Figure 4.15

## 4.12 PROCEDURES BUTTON

The *EPIC X* has the ability to store up to 20 pre-set procedures; *EPIC X* is factory-installed with 14 pre-programmed procedural presets and 6 empty slots for custom pre-sets. All of them can be customized to your preference.

To customize the parameters (e.g., power, pulse duration, interval, etc.) for a particular clinical procedure:

1. Go to the PROCEDURES menu by pressing the Soft Tissue icon  on the HOME screen; scroll to and select the pre-set you wish to overwrite (Figure 4.16).
2. Press and hold the banner on the selected procedure for two (2) seconds (Figure 4.17). The parameters for that procedure will be changed and saved (the laser console will beep when the adjusted settings are saved).



Figure 4.16

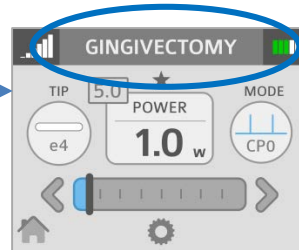



Figure 4.17

## 4.13 TURN THE LASER CONSOLE OFF

- Wind the fiber cable onto the fiber spool counterclockwise around the base of the console.
- Place the Handpiece onto the Handpiece holder. 

### CAUTION:

Verify that the fiber optic tubing assembly is not twisted once the Handpiece is returned to the holder. The fiber may break if it is twisted.

- Press the CONTROL button on the front of the console for more than 2 seconds to turn the display off.
- Press the Power Switch at the rear of the laser console to the OFF (O) position if the laser system will not be used for a long period of time.

## 5. Specifications

### 5.1 GENERAL

Dimension	5.7 in (W) x 4.4 in (H) x 6.5 in (L) (14.5 cm x 11.2 cm x 16.5 cm)
Weight	2.5 lbs / 1kg

### 5.2 ELECTRICAL

Operating Voltage	100V - 240V ~ at 1.5A
Frequency	50/60Hz
External Fuses	None
Main Control	Power Switch
Remote Interruption	Remote Interlock
Disable Control	Emergency Stop Button
Battery	Lithium Ion Rechargeable, 14.4V, 2.9Ah
DC Power Supply Module	12V DC, 5A

### 5.3 LASER

Laser Classification	IV (4)
Medium	InGaAsP Semi-conductor diode
Wavelength	940 ± 10nm
Max Power Output	10W
Power Accuracy	± 20%
Power Modes	Continuous, Pulse Modulation
Fiber Tips Diameter	200µm, 300 µm, 400µm
Pulse Duration	0.01ms – 20ms

Pulse Interval	0.01ms – 20ms
Pulse Repetition Rate	Up to 20kHz (for reference)
Spot size	
Surgical Handpiece	400µm (maximum in contact mode)
Deep Tissue Handpiece	30mm diameter = 7.1cm <sup>2</sup> area
Whitening Handpiece	Rectangular 35mm x 8mm = 2.8cm <sup>2</sup>
NOHD	4.77 meters
Beam Divergence	8 - 22° per side angle
Standard Fiber Cable Length	5 feet (1.524 meters)

#### **5.4 OTHER LIGHT SOURCES**

Aiming Beam	Laser diode, max 1 mW, 625 nm – 670 nm, Class 2
-------------	---

## 6. Contraindications, Warnings & Precautions

### 6.1 CONTRAINDICATIONS

All clinical procedures performed with *EPIC X* must be subjected to the same clinical judgment and care used with traditional techniques. Patient risk must always be considered and fully understood before clinical treatment. The clinician must completely understand the patient's medical history prior to treatment. Exercise caution for general medical conditions that might contraindicate a local procedure. Such conditions may include allergy to local or topical anesthetics, heart disease (including pacemakers and implantable defibrillators), lung disease, bleeding disorders, sleep apnea or an immune system deficiency, or any medical conditions or medications that may contraindicate use of certain light/laser type sources associated with this device. Medical clearance from patient's physician is advisable when doubt exists regarding treatment.

### 6.2 WARNINGS AND PRECAUTIONS

#### *Prescription Statement*

Federal Law restricts this device to sale by or on the order of a dentist or physician or other licensed medical practitioner.

#### *Eyewear*

Doctor, patient, assistant and all others inside the operatory must wear appropriate laser eyewear protection for the diode laser wavelength of  $940 \pm 10\text{nm}$ .

#### *Anesthesia*

In soft tissue cases anesthesia may not be required, but patients should be closely monitored for signs of pain or discomfort at all times. If such signs are present, adjust settings, apply anesthesia or cease treatment if required.

#### *Adjacent Structures*

*EPIC X* is designed to remove soft tissues. Therefore, always be aware of adjacent structures and substructures during use. Be extremely careful not to inadvertently penetrate or ablate underlying or adjacent tissues. Do not direct energy toward hard tissue such as tooth or bone. Do not direct energy towards amalgam, gold or other metallic surfaces. Do not direct energy towards cements or other filling materials. Exercise extreme caution when using this device in areas such as pockets, cavities or channels such as third molar sockets, where critical structures (i.e. nerves, vessels) could be damaged. Do not proceed with using the laser if visibility is limited in these areas.

#### *Suction*

Use high-speed suction as required to maintain a clear field of vision during treatment. Do not fire the laser if you cannot clearly see the treatment site.

### *Plume Removal*

Special care must be taken to prevent infection from the laser plume generated by vaporization of virally or bacterially infected tissue. Ensure that appropriate protective equipment (including high-speed suction to remove the plume, appropriately filtered masks, and other protective equipment) is used at all times during the laser procedure.

### *Clinical Use*

Use your clinical judgment to determine all aspects of treatment including, but not limited to, the laser treatment protocol, technique, power settings, pulse duration and interval settings, mode of operation as well as the accessories (e.g. tip type) and other procedural requirements. Closely observe and monitor clinical effects and use your judgment to determine clinical parameters and approach for the treatment. Make appropriate power, pulse length, and interval adjustments to compensate for varying tissue compositions, density, and thickness. Always start treatment at the lowest power setting for that specific indication and increase as required. BIOLASE assumes no responsibility for parameters, techniques, methods or results.

### *Training*

Only licensed professionals who have reviewed and understood this User Manual should use this device. BIOLASE assumes no responsibility for parameters, techniques, methods, or results. Physicians must use their own clinical judgment and professionalism in determining all aspects of treatment, technique, proper power settings, interval, duration, etc.



**LASER  
WARNING:**

Never point the laser at a person's eyes. All persons present in the operatory must wear protective eyewear when the laser is in operation

# 7. Clinical Applications

## 7.1 INTRODUCTION

To efficiently remove tissues it is imperative to understand the nature of the *EPIC X* device. Please review this section carefully, practice on model tissues, and attend a diode laser training session before using this device in a clinical situation.

## 7.2 INDICATIONS FOR USE

Use of the *EPIC X* device may be appropriate for incision, excision, vaporization, ablation and coagulation of oral soft tissues including marginal and inter-dental gingival and epithelial lining of free gingiva and the following specific indications:

- Excisional and incisional biopsies
- Exposure of unerupted teeth
- Fibroma removal
- Frenectomy
- Frenotomy
- Gingival troughing for crown impressions
- Gingivectomy
- Gingivoplasty
- Gingival incision and excision
- Hemostasis and coagulation
- Implant recovery
- Incision and drainage of abscess
- Leukoplakia
- Operculectomy
- Oral papillectomies
- Pulpotomy
- Pulpotomy as an adjunct to root canal therapy
- Reduction of gingival hypertrophy
- Soft tissue crown lengthening
- Treatment of canker sores, herpetic and aphthous ulcers of the oral mucosa
- Vestibuloplasty
- Tissue retraction for impression
- Laser soft tissue curettage
- Laser removal of diseased, infected, inflamed and necrosed soft tissue within the periodontal pocket
- Sulcular debridement (removal of diseased, infected, inflamed and necrosed soft tissue in the periodontal pocket to improve clinical indices including gingival index, gingival bleeding index, probe depth, attachment loss and tooth mobility.)
- Light activation for bleaching materials for teeth whitening
- Laser-assisted whitening/bleaching of teeth
- Topical heating for the purpose of elevating tissue temperature for a temporary relief of minor muscle and joint pain and stiffness, minor arthritis pain, or muscle spasm, minor sprains and strains, and minor muscular back pain; the temporary increase in local blood circulation; the temporary relaxation of muscle.



### 7.3 SOFT TISSUE SURGERY AND OTHER DENTAL USE

*Tip Initiation: Parameters and Method (Not required if using pre-initiated tips)*

Most soft tissue surgical procedures require initiation of the fiber tip. **The TIP INITIATION screen will appear (in READY mode) if tip initiation is recommended** and the system will automatically go to the settings shown in Figure 7.1 based on the tip used; while in the TIP INITIATION screen, initiate the tip by following the steps outlined below.

Tip Diameter (µm)	(Preset) Power (W)	Mode
400	1.4	CW
300	1.4	CW
200	Tip initiation not required when used for recommended procedures	

Figure 7.1

- Touch the tip to the surface of the initiation block, without activating the laser (don't press down on the footswitch (Figure 7.2).
- Press the footswitch to activate the laser, allowing the tip to sink into the block. Pull the tip out when the metal cannula touches the block, still firing until just before the tip is out of the block (Figure 7.3).
- Press the footswitch to activate the laser into the air once; a white flash will be visible or the tip will glow (Figure 7.4).
- Repeat initiation process as needed to ensure the tip is initiated.



Figure 7.2



Figure 7.3



Figure 7.4

After tip initiation is completed, press the check mark to access the screen for the selected procedure.

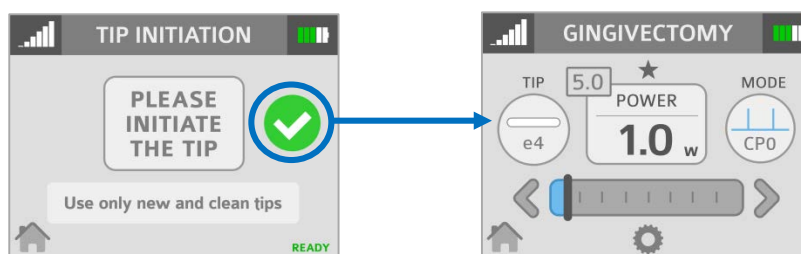



Figure 7.5

**CAUTION:**

If the laser console is in "READY" mode, the laser will fire if the footswitch is activated.

## Pre-programmed Settings for Dental Procedures

To access the pre-programmed procedure values:

1. Go to the Procedures menu by pressing the Soft Tissue icon  on the Home screen.
2. Press the button associated with the desired procedure.
3. Press the up and down arrows  to scroll for additional procedures.

To store your personal preferred settings for any procedure:

- A. Follow steps 1 and 2 above.
- B. Enter the new values.
- C. Touch and hold the Procedure name for more than 2 seconds; you will hear a beeping sound confirming the settings are saved.

### NOTE:

The Procedure Pre-Sets installed at the factory are based on clinical recommendations and feedback from experienced laser dentists.

300 $\mu$ m tips are recommended for removing thin tissue layers. 400 $\mu$ m tips are recommended for removing fibrous tissue.

Always use clinical judgment when selecting power, pulse, length, and pulse interval parameters to ensure optimal clinical results. **The recommended settings apply only to the 300 $\mu$ m and 400 $\mu$ m tips.** At all times observe the clinical effects on the treatment area and adjust parameters accordingly.

## 7.4 TABLE OF PRE-PROGRAMMED SETTINGS

	Preset Name	Indications for Use	Mode	Peak Power	Avg. Power	Pulse Interval	Pulse Length	Duty Cycle	Tip Type	Tip Initiated?
1	Gingivectomy/Gingivoplasty	Reduction of gingival hypertrophy, Vestibuloplasty	CP0	5.0 W	1.0 W	0.04 ms	0.01 ms	20%	E4	Yes
2	Troughing	Tissue retraction for impression, Gingival troughing for crown impressions	CP2	2.0 W	1.0 W	1.0 ms	1.0 ms	50%	E4	Yes
3	Curettage	Laser soft tissue curettage	CP1	2.4 W	0.8 W	0.2 ms	0.1 ms	30%	E4	Yes
4	Excision	Fibroma removal, Excisional and incisional biopsies, Gingival incision and excision, Operculectomy, Oral papillectomies, Incision and drainage of abscess	CP1	2.7 W	0.9 W	0.2 ms	0.1 ms	30%	E4	Yes
5	Frenectomy/Frenotomy	Frenectomy/Frenotomy	CP2	2.0 W	1.0 W	1.0 ms	1.0 ms	50%	E4	Yes
6	Implant Recovery	Implant Recovery	CP2	2.4 W	1.2 W	1.0 ms	1.0 ms	50%	E4	Yes
7	Perio Pockets	Sulcular debridement (removal of diseased, infected, inflamed and necrosed soft tissue in the periodontal pocket to improve clinical indices including gingival index, gingival bleeding index, probe depth, attachment loss and tooth mobility.)	CP2	1.6 W	0.8 W	1.0 ms	1.0 ms	50%	E3	No
8	Pulpotomy(*)	Pulpotomy, Pulpotomy as an adjunct to root canal	CW	0.1 W	0.1 W	N/A	N/A	N/A	E4	Yes
9	Crown Lengthening	Soft tissue crown lengthening	CP1	2.7 W	0.9 W	0.2 ms	0.1 ms	30%	E4	Yes
10	Infected Pockets	Laser removal of diseased, infected, inflamed and necrosed soft tissue within the periodontal pocket	CP2	1.6 W	0.8 W	1.0 ms	1.0 ms	50%	E4	Yes
11	Endo (*)	Pulpotomy, Pulpotomy as an adjunct to root canal	CW	0.1 W	0.1 W	N/A	N/A	N/A	E2	No
12	Hemostasis	Hemostasis	CW	0.5 W	0.5W	N/A	N/A	N/A	E4	Yes
13	Apthous Ulcers	Treatment of canker sores, herpetic and apthous ulcers of the oral mucosa, Leukoplakia	CW	0.7 W	0.7 W	N/A	N/A	N/A	E4	No
14	Exposure of Unerupted Teeth	Exposure of unerupted teeth	CP2	1.8 W	0.9 W	N/A	N/A	N/A	E4	Yes
15-17	Custom 1-3	N/A	CW	0.1 W	0.1 W	N/A	N/A	N/A	E4	Yes
18-20	Custom 4-6	N/A	CW	0.1 W	0.1 W	N/A	N/A	N/A	E4	No

(\*)Minimum defaults provided for user setting of Endodontic Procedures such as Pulpotomy and Pulpotomy as an adjunct to root canal therapy.

Figure 7.6

## 7.5 TEETH WHITENING PROCEDURE

The following items are required to perform teeth whitening with the *EPIC X* laser:

*EPIC X* diode laser

Whitening/Contour Handpiece (Optional Accessory).

Laserwhite™ 20 Whitening Gel Kit, BIOLASE p/n 7400030, sold separately in packs of five (Figure 7.7).

Detailed step-by-step instructions, contraindications, precautions, and warnings for teeth whitening are provided with the Laserwhite™ 20 Whitening Gel Kit. Please read the instructions carefully before proceeding.



Figure 7.7 Laserwhite™ 20 Whitening Gel Kit (BIOLASE PN 7400030)

## 7.6 PAIN THERAPY

The *EPIC X* diode laser is designed to provide near-infrared laser energy to a tissue surface for the purpose of temporary pain relief when applied with the Whitening/Contour or Deep Tissue Handpiece. The pain therapy procedure is the process by which tissue temperature is elevated for the temporary relief of minor pain, the temporary increase in local blood circulation, and the temporary relaxation of muscle, as stated in the Indications for Use.

Affected muscles and/or joints have to be exposed to an adequate level of therapeutic energy over a short period of time to provide effective therapeutic effects. Some patients may require more than one laser application or a series of treatments before significant improvement is reported. Repeat the therapy as necessary and monitor the progress of the patient's condition throughout the treatment.

Refer to the Fitzpatrick Skin Type Scale when performing pain therapy procedures. The diode wavelength has increased absorption in melanin in the skin, causing greater heating of the skin surface of patients with a higher melanin concentration (darker skin types). Patients with higher melanin content in their skin may feel more discomfort during treatment, which may be alleviated by moving the Handpiece, defocusing the energy, or decreasing the power setting.

Fitzpatrick Skin Type Scale	
<b>TYPE I</b>	Highly sensitive, always burns, never tans. Example: Red hair with freckles
<b>TYPE II</b>	Very sun-sensitive, burns easily, tans minimally. Example: Fair-skinned, fair-haired Caucasians
<b>TYPE III</b>	Sun-sensitive skin, sometimes burns, slowly tans to light brown. Example: Darker Caucasians
<b>TYPE IV</b>	Minimally sun-sensitive, burns minimally, always tans to moderate brown. Example: Mediterranean-type Caucasians
<b>TYPE V</b>	Sun-insensitive skin, rarely burns, tans well. Example: Some Hispanics, some Blacks
<b>TYPE VI</b>	Sun-insensitive never burns, deeply pigmented. Example: Darker Blacks

Figure 7.8

### *Pain Therapy – Adverse Effects*

Some reddening of the skin at the treatment site is normal due to increased circulation; however, in very rare cases burning or blistering of the skin may occur. **Immediately stop treatment**, rinse the area with cool water or place a cold pack to the affected area for at least 5 minutes, then apply a burn ointment or spray. **DO NOT USE ICE.**

Patients should be monitored for discomfort and visual skin changes. Redness has been associated with increased temperature at the site of application and increased absorption properties of the skin. If discomfort or redness of the skin occurs at any time during the treatment, you have the following options:

- Move the handpiece relative to the affected anatomy
- Defocus the energy by moving the Handpiece further away from the skin
- Decrease the power setting
- Stop treatment

### *Pain Therapy – Warnings and Precautions*

- Scar tissue has been associated with poor circulation and reduced cooling through heat transport by blood; power settings may have to be reduced to avoid overheating.
- Patients with tender or sensitive skin may be hypersensitive to heat; reduce power as necessary to ensure comfort during treatment.
- Patients with swelling and/or inflammation may be sensitive to heat; reduce power as necessary to ensure comfort during treatment.
- Do not treat open wounds.
- Muscle tissue closer to the skin surface may experience a higher absorption of heat; carefully monitor skin temperature and reduce power as necessary.
- Excessive fatty tissue is known to transmit heat without much attenuation; reduce power.
- Different implant materials will respond differently to laser energy and heat; be aware of any implants and their location; avoid direct exposure to laser energy or heat at the site of the implant.

- Avoid treatment of sites that have tattoos.
- Do not apply ointment, creams, lotions or heating lotion patches at, or in close proximity to, the treatment area.
- Do not apply therapies prior to treatment that could change body temperature, such as ultrasound, ice/heat pack, electrical stimulation, or heating patches.
- Do not apply treatment over articles of clothing.

### *Recommended Use*

There are four main variables that impact the safety and effectiveness of pain therapy procedures:

- Power output
- Distance from the skin surface
- Range of movement of the Handpiece
- Patient skin type

Safety and effectiveness are described by elevating the skin temperature in the treatment area utilizing the settings recommended below. Use personal clinical judgment with consideration of the Fitzpatrick Skin Type Scale when selecting procedure parameters; monitor the patient and adjust the settings as necessary for effectiveness and patient comfort.

**NOTE:** To avoid potential patient discomfort and/or skin damage, it is advisable to use a test spot prior to the initial treatment to assess the suitability of the selected settings for the individual patient.

### *Using the Deep Tissue Handpiece*

If holding the Handpiece in a constant location, adjust the settings on the screen to the recommended initial power settings for therapeutic effect, 4.0W, delivered over 10 minutes (600 seconds) of continuous treatment (CW), with the spacer set at a 30mm spot size. Always monitor patient response; adjust power and/or distance as needed for patient comfort.

## 8. Maintenance

**WARNING:** No modification of this equipment is allowed.

### 8.1 DAILY MAINTENANCE

Use the peel-off clear covers for the laser console supplied with the system. Use disinfectant to wipe down the front panel and Handpiece holder of the *EPIC X* system after each procedure. **Do not use bleach or abrasive cleansers.**

### 8.2 CLEANING AND STERILIZATION PROCEDURES

The contamination control suggested for the *EPIC X* Surgical Handpiece and tips is the steam sterilization method. However, before sterilization, the *EPIC X* reusable Handpiece should be MANUALLY cleaned per the following procedure.

**CAUTION:**

Handpiece and tips must be cleaned and sterilized prior to initial use.

**Tips are single-use only** to avoid cross-contamination and are designed to withstand a single sterilization cycle; they must be disposed of after use in a biohazard medical waste Sharps container.

Handpieces are reusable and must be cleaned and sterilized between patients to avoid cross-contamination.

#### *Cleaning and Disinfecting Instructions-Surgical Handpiece, Reusable Fiber Optic Cable*

The cleaning process is intended to remove blood, protein and other potential contaminants from the surfaces and crevices of reusable accessories. This process may also reduce the quantity of particles, microorganisms and pathogens present. Cleaning should be performed prior to sterilization and must be conducted only by qualified office personnel trained to perform the procedure and handle the *EPIC X* fiber optic delivery system.

Wear protective latex gloves when handling the contaminated delivery system.

To disinfect the fiber cable, wipe the entire cable, including the shaft, with an appropriate disinfecting solution, such as Cavicide™ or a similar quaternary ammonium compound product (containing 20% alcohol or less), and follow the manufacturer's instructions. Avoid getting any liquid or debris near the distal end of the fiber cable.

#### *Manual Cleaning of the Surgical Handpiece*

**Cleaning must be performed within a maximum of 1 hour after the procedure and always prior to sterilization.**

1. After use, carefully remove the tip from the Handpiece and dispose of in a biohazard medical waste Sharps container.
2. Carefully remove the Handpiece from the fiber optic cable (see Section 2).

3. Prepare any commercially available surgical instrument detergent/enzymatic cleaning solution with a pH of 7.0, such as Enzol® or similar enzymatic presoak and cleaner, per the manufacturer's instructions. (Follow the manufacturer's instructions for disposal of used solution.)
4. Rinse the Handpiece under running lukewarm tap water (22 – 43°C) for a **minimum of 10 seconds** to remove gross soil.
5. Wrap the Handpiece in a piece of gauze that has been soaked in the cleaning solution; leave it wrapped in the gauze for a **minimum of 10 minutes**.
6. Unwrap the Handpiece from the gauze and use a soft-bristled brush dipped in the cleaning solution to gently scrub it for **at least 15 seconds**.
7. Rinse the Handpiece under running lukewarm tap water (22-43°C) for a **minimum of 10 seconds** and then dry with a lint-free cloth.
8. Visually inspect the Handpiece for any residual soil. If necessary, repeat steps 5 - 7 until **all** residual soil is removed.

### Steam Sterilization for Surgical Handpiece, Single Use Tips

The steam sterilization process is intended to destroy infectious microorganisms and pathogens.

**NOTE:** Always perform the procedure immediately *after* cleaning and *prior* to use and **only** use FDA-cleared (USA) or CE-marked (Europe) sterilization accessories, *i.e.*, sterilization pouch and autoclave tray.

- Place the Handpiece and fiber tips in separate single-wrap, self-seal autoclave pouches.
- Place on an autoclave tray; do not stack other instruments on top of the pouches.
- Place the tray inside the autoclave chamber and set the appropriate cycle as recommended in Figure 8.1.

Type of Sterilizer	Temperature	Minimum Time	Drying Time
Gravity Displacement	121°C ( 250°F)	30 minutes	15 – 30 minutes
	132°C (270°F)	15 minutes	
Dynamic-Air-Removal (Pre-Vacuum)	132°C (270°F)	4 minutes	20 – 30 minutes
	134°C (EU only)		

Figure 8.1

- Once the cycle is completed, remove the tray and let each sterilized item cool and dry. **The Handpiece and tips must remain in the sterilization pouches until used in order to maintain sterility.**
- For instructions on how to reassemble the Handpiece, please refer to section 2.7.



### *Disinfecting the Whitening/Contour Handpiece*

The Whitening Handpiece is sold with disposable non-sterile protective shields.

**The Handpiece and clear protective shield are not autoclavable.** The clear protective shields are intended for one-time use only and should never be reused to prevent cross-contamination.

To disinfect the Whitening Handpiece, wipe down the Handpiece with gauze and isopropyl alcohol. Always wipe the disposable shield with alcohol prior to use. Dispose of after single use.

### *Disinfecting the Deep Tissue Handpiece*

The Deep Tissue Handpiece is sold with non-sterile, disposable protective shields.

**The Handpiece and clear protective shield are not autoclavable.** The clear protective shields are intended for single-time use only and should never be reused to prevent cross-contamination.

To disinfect the Deep Tissue Handpiece, wipe the entire outer surface of the Handpiece with cotton gauze and isopropyl alcohol or a mild chemical disinfectant.

Always wipe the disposable shield with alcohol prior to use. Dispose of after one-time use.

## **8.3 INSTALLING/REPLACING THE CONSOLE BATTERY PACK**

1. To install or replace the battery pack, remove the battery cover on the underside of the console using the Phillips screwdriver included with the laser system (Figure 8.2).
2. To remove the battery, grip the battery at the top and pull the cable away from the connector (Figure 8.3). Do not tug or wrench the cable from the connector.
3. To install the battery, insert the connector wire from the battery to the unit, making sure the red wire is on the left, and gently place the battery into the compartment (Figure 8.3).
4. Replace the battery cover on the bottom of the unit, using a standard Phillips screwdriver.
5. Connect the power cord of the DC power supply to the unit and plug into a wall outlet. Before first use, you should fully charge the battery (at least three (3) hours). Once the battery is charged, unplug the power cord from the wall outlet and the console. The unit will run on battery power alone. (See Section 4.1)
6. Recycle the used Lithium Ion battery as regulated. Do not throw it in a trash bin.

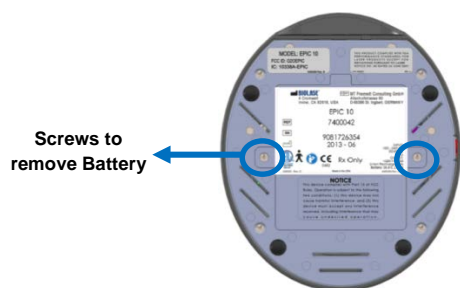

Figure 8.2: Batter Cover/Bottom of Console

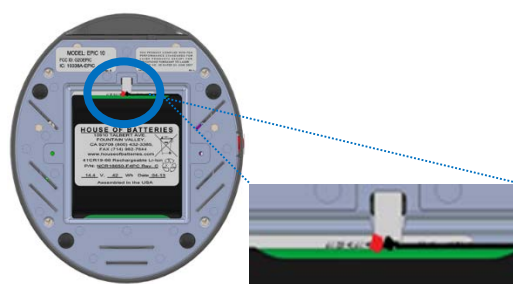

Figure 8.3: Battery Pack/Connector Wire

**NOTE:** Only use the battery pack supplied by BIOLASE. The battery pack is a separate accessory (BIOLASE p/n 6400457).

## 8.4 CHANGING THE WIRELESS FOOTSWITCH BATTERIES

The wireless footswitch is powered by two AAA batteries. When the batteries are low, a warning message will appear on the touchscreen indicating that the batteries need to be replaced. To replace the batteries, unscrew the battery cover on the underside of the footswitch (Section 4), remove the old batteries, and install the new ones, replacing the cover when done. Dispose of the used batteries as regulated; do not throw them in a trash bin.

Do not press/push/touch the Pairing Button (Figure 8.4) while changing the batteries, as this will disrupt the pairing of the laser console and footswitch.

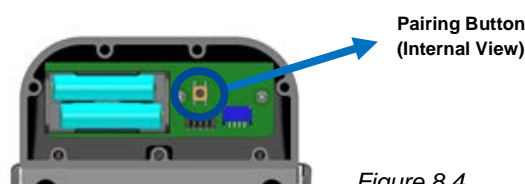

Figure 8.4

Replacing the batteries may disrupt the pairing of the laser console and footswitch. If you find the wireless communication has been interrupted, reestablish pairing by following the instructions provided in Section 4.

**NOTE:** To ensure the longevity of the battery power, only BIOLASE-supplied batteries are recommended as replacements (BIOLASE p/n 6400463); these are industrial-grade batteries which under normal use have a longer life than conventional AAA batteries.

## 8.5 TRANSPORTATION

The *EPIC X* is susceptible to damage if not handled properly. The unit should ALWAYS be handled carefully and never banged, jarred, jolted, dropped, or knocked.

Do not transport the unit unless it is completely packaged inside its shipping box. If you have any questions regarding transportation please call BIOLASE Service at 1-800-321-6717.

## 8.6 STORAGE

The *EPIC X* should be stored in a cool, dry place when not in use (*storage temperature*: 15°C-35°C (59°F-95°F), *relative humidity*: 10%-70%, non-condensing). Cover the unit when not in use for extended periods of time. Store the system in a place where it will not be accidentally bumped or banged.

**CAUTION:** Make sure the distal end of the Handpiece shaft is protected from dirt by installing the Handpiece and protective tip plug  
**Remove the batteries from the footswitch if the *EPIC X* is not likely to be used for some time.**

The *EPIC X* is shipped inside a custom shipping box. Please save and store the box in a cool, dry place for use when transporting the laser, or for long-term storage.

## 9. Calibration

Calibration procedure is recommended to be performed every twenty-four (24) months in order to maintain the required accuracy of output power versus displayed power. Bi-annual calibrations can be performed at a certified depot repair facility. Call BIOLASE Service at 1-800-321-6717 or your Authorized Service Representative to schedule an appointment.

## 10. Software Specification

BIOLASE respects the intellectual property of others, and we ask our users to do the same. *EPIC X* software is protected by copyright and other intellectual property laws.

This product contains proprietary, copyrighted software developed by BIOLASE, Inc. All rights reserved in the USA and other countries.

## 11. Troubleshooting

Should any of the on-screen messages listed in Figure 11.1 and Figure 11.2 appear, follow the troubleshooting instructions for the specific message as noted below.

**NOTE:** For any on-screen message not listed in Figure 11.1, re-power the laser console; if the message does not clear, call **BIOLASE Service at 1-800-321-6717** or your authorized Service Representative











Screen	Message 	Reason 	Fix 
Warning 1 	Temperature high	System is hot	Allow 5-10 minutes for laser to cool down
Warning 2 	Battery is low	Battery is low	Plug in DC supply
Warning 3 	Battery not connected	Battery not connected	Plug in the battery
Warning 4 	Footswitch battery is low	Battery on the footswitch is low	Replace footswitch battery
Warning 5 	Footswitch	Footswitch held	Release footswitch
Alert 1 	Wireless not paired	No wireless connection	Re-establish pairing (see sec 4)
Alert 2 	System must be in ready mode to lase	System is not in ready mode	Press the control button in any procedure screen

Figure 11.1















Screen	Message 	Reason 	Fix 
Error 1 	Thermistor open	Thermistor open	Call Biolase service
Error 2 	Thermistor shorted	Thermistor shorted	
Error 3 	Shutdown temperature	System too hot	Allow 5-10 minutes for laser to cool down
Error 4 	Laser current high/low	Output is out of specs	Call Biolase service
Error 5 	Footswitch shorted	FS is partially pressed or damaged	Press/release footswitch or call Biolase service
Error 6 	ON/OFF button stuck	Key stuck	Press front key
Error 7 	Flash corrupted	Memory corrupted	Call Biolase service
Error 8 	No fiber	Fiber not inserted	Plug in trunk fiber
Error 9 	Lost footswitch communication	Wireless interference	Reposition console or footswitch to improve communication
Error 10 	Emergency switch	E-switch pressed	Press E-switch again
Error 11 	Remote interlock	Remote interlock open	Check remote interlock closed
Error 12 	Battery critically low	Battery is critically low	Plug in dc supply
Error 13 	Internal error	Internal error occurred	Restart unit
Error 14 	Footswitch battery	Footswitch battery critically low	Replace footswitch battery

Figure 11.2

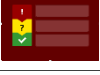
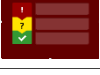
## APPENDIX A – Tip Guide and Accessories

Tip	Name	Diameter (µm)	Length (mm)	Qty	Application	Part Number
	E4-4	400µm	4	30	Surgical	7400016
	E4-7	400µm	7	15	Perio	7400019 Combo Pack 15 x E4-7, 15 x E4-9
	E4-9	400µm	9	15		
	E3-4	300µm	4	30	Surgical	7400017
	E3-7	300µm	7	15	Perio	7400020 Combo Pack 15 x E3-7, 15 x E3-9
	E3-9	300µm	9	15		
	E2-4	200µm	4	30	Surgical	7400018
	E2-14	200µm	14	30	Endo	7400021
	E2-20	200µm	20	20	Endo	7400015

**NOTE:** All Biolase tips for diode lasers are sold non-sterile and are for single-use only. See Section 8.2 for sterilization instructions.

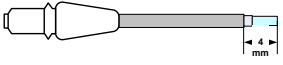
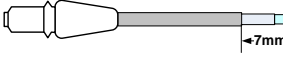
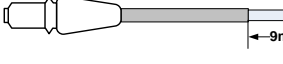
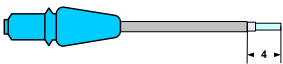
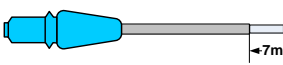
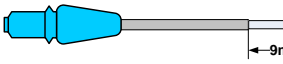
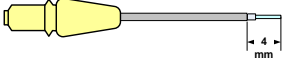
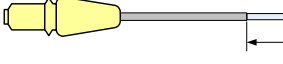
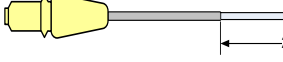
Part No.	Description	Part No.	Description
6400479	Surgical Handpiece (2-pack)	7400030	Laserwhite 20 Whitening Gel Kit (5-pack)
2400040	Laser safety glasses (Clinician)	6400311	Deep-Tissue Handpiece
6400058	Remote Interlock plug	6400310	Deep Tissue Handpiece protective covers (qty. 20)
2400129	Power cord with power supply	6400465	Peel-off clear screen covers (qty. 20)
6400573	Wireless footswitch	6400457	Lithium-ion battery pack for console
6400107	Tip initiation kit	6400463	Battery pack (2 x AAA)
7400022	Whitening/Contour Handpiece	6400437	Trunk Fiber assembly
6400180	Disposable shields for Whitening Handpiece (30-pack)	5400386	Laser warning sign

# APPENDIX B – Labeling

## CONSOLE

<p><b>Product ID Label</b> Location: Bottom of laser console</p>	<p><b>Manufacturer</b></p>	<p><b>Date of Manufacture</b></p>	<p><b>Catalog/Part Number</b></p>	<p><b>Product Serial Number</b></p>	<p><b>Refer to User Manual</b></p>	<p><b>Type B Applied Part:</b> The applied part is not conductive to the patient</p>

<p><b>Warning Label:</b> Indicates there is the risk of possible exposure to both infrared and visible laser radiation. Location: Back of laser console</p>	<p><b>Laser Warning:</b> Indicates the system contains a laser. Location: Back of Laser Console</p>	<p><b>Fiber Warning:</b> Indicates the laser aperture is at the end of the fiber. Location: Back of Laser Console</p>	<p><b>Emergency Laser Stop Switch:</b> The switch used in emergencies to stop laser output. Location: Right side of Laser Console</p>	<p><b>FCC and IC Label:</b> Lists Federal Communication Commission and Industry Canada registration numbers. Location: Bottom of Laser Console</p>	<p><b>FDA Compliance Label:</b> Indicates product complies with FDA performance standards. Location: Bottom of Laser Console</p>

<p><b>DC Power, USB, Remote Interlock Label:</b> Identifies input ports</p>	<p><b>Power Input Rating:</b> 12 Volts Direct Current, 5 amps</p>	<p><b>Mini USB Input:</b> For external programming</p>	<p><b>Remote Interlock:</b> Input for Remote Interlock Connector</p>

# FOOTSWITCH

	<h2>IPX6</h2>	<p><b>NOTICE</b> This device complies with Part 15 of FCC Rules. Operation is subject to the following two conditions: (1) this device may not cause harmful interference, and (2) this device must accept any interference received, including interference that may cause undesired operation.</p>	<p><b>MODEL: EPIC X</b> FCC ID: G20EPIC-1 IC: 10338A-EPIC 5400583 Rev. A</p>
<p><b>Footswitch Product ID Label Location:</b> Bottom of footswitch</p>	<p><b>Ingress Protection Code:</b> The footswitch is water-resistant, protected against splashes of water.</p>	<p><b>FCC Compliance Notice:</b> The footswitch and laser console comply with Part 15 of FCC Rules regarding unlicensed transmissions. <b>Location:</b> Bottom of Footswitch</p>	<p><b>FCC and IC Label:</b> Lists Federal Communication Commission and Industry Canada registration numbers. <b>Location:</b> Bottom of Footswitch</p>

## TIPS

**DO NOT REUSE**  
For single use only.

## BATTERY

**WEEE (Waste Electrical and Electronic)**  
Recycle Lithium Ion battery as regulated. Do not throw in trash bin.

## PACKAGING

<p><b>Prescription Statement:</b> Federal Law restricts this device to sale by or on the order of a dentist or physician or other licensed medical practitioner.</p>	<p><b>Atmospheric Pressure Limitations</b></p>	<p><b>Keep Dry</b></p>	<p><b>Fragile:</b> Handle with care</p>	<p><b>Humidity Limitations</b></p>	<p><b>Temperature Limitations</b></p>	<p><b>This End UP</b></p>

## APPENDIX C – Safety Precautions for Lithium-Ion Battery Packs

### When using the battery:

#### WARNING

1. Misusing the battery may cause the battery to get hot, rupture, or ignite and cause serious injury. Be sure to follow the safety rules listed below:
  - Do not place the battery in fire or heat the battery.
  - Do not install the battery backwards so that the polarity is reversed.
  - Do not connect the positive terminal and the negative terminal of the battery to each other with any metal object (such as a wire).
  - Do not carry or store the batteries together with necklaces, hairpins, or other metal objects.
  - Do not pierce the battery with nails, strike the battery with a hammer, step on the battery, or otherwise subject it to strong impacts or shocks.
  - Do not solder directly onto the battery.
  - Do not expose the battery to water or salt water, or allow the battery to get wet.
2. Do not disassemble or modify the battery. The battery contains safety and protection devices which, if damaged, may cause the battery to generate heat, rupture, or ignite.
3. Do not place the battery on or near fires, stoves, or other high-temperature locations. Do not place the battery in direct sunshine or use or store the battery inside cars in hot weather. Doing so may cause the battery to generate heat, rupture, or ignite. Using the battery in this manner may also result in a loss of performance and a shortened life expectancy.

#### CAUTION

1. If the device is to be used by small children, the caregiver should explain the contents of the user's manual to the children. The caregiver should provide adequate supervision to ensure that the device is being used as explained in the user's manual.
2. When the battery is worn out, insulate the terminals with adhesive tape or similar materials before disposal.
3. Immediately discontinue use of the battery if, while using, charging, or storing the battery, the battery emits an unusual smell, feels hot, changes color, changes shape, or appears abnormal in any other way. Contact your sales location or BIOLASE if any of these problems are observed.
4. Do not place the batteries in microwave ovens, high-pressure containers, or on induction cookware.



5. In the event that the battery leaks and the fluid gets into one's eye(s), do not rub the eye(s). Rinse well with water and immediately seek medical care. If left untreated, the battery fluid could cause damage to the eye.

### When charging the battery:

#### WARNING

1. Be sure to follow the rules listed below while charging the battery. Failure to do so may cause the battery to become hot, rupture, or ignite and cause serious injury.
  - When charging the battery, either use a specified battery charger or otherwise ensure that the battery charging conditions specified are met.
  - Do not attach the batteries to a power supply plug or directly to a car's cigarette lighter.
  - Do not place the batteries in or near fire, or into direct sunlight. When the battery becomes hot, the built-in safety equipment is activated, preventing the battery from charging further, and heating the battery can destroy the safety equipment and can cause additional heating, breaking, or ignition of the battery.
2. Do not continue charging the battery if it does not recharge within the specified charging time. Doing so may cause the battery to become hot, rupture, or ignite.

#### CAUTION

The temperature range over which the battery can be charged is 0°C to 45°C. Charging the battery at temperatures outside of this range may cause the battery to become hot or to break. Charging the battery outside of this temperature range may also harm the performance of the battery or reduce the battery's life expectancy.

### When discharging the battery:

#### WARNING

Do not discharge the battery using any device except for the specified device. When the battery is used in devices aside from the specified device it may damage the performance of the battery or reduce its life expectancy, and if the device causes an abnormal current to flow, it may cause the battery to become hot, rupture, or ignite and cause serious injury.

#### CAUTION

The temperature range over which the battery can be discharged is -20°C to 60°C. Use of the battery outside of this temperature range may damage the performance of the battery or may reduce its life expectancy.

## APPENDIX D – Electromagnetic Compatibility

**CAUTION:**

Medical electrical equipment needs special precautions regarding electromagnetic compatibility (EMC) and needs to be installed and put into service according to the EMC information provided in the following tables.

Portable and mobile Radio Frequency (RF) communications equipment can affect medical electrical equipment.

Accessories: Medical grade power cord, maximum length 3ft (1 meter), Biolase p/n 2400043.

Footswitch: Wireless, Biolase p/n 6400146

**WARNING:**

The use of accessories, other than those specified, except those supplied or sold by Biolase, Inc. as replacement parts for internal or external components, may result in increased EMISSIONS or decreased IMMUNITY of the EPIC diode laser system.

### GUIDANCE AND MANUFACTURER’S DECLARATION – ELECTROMAGNETIC EMISSIONS

The EPIC diode laser is intended for use in the electromagnetic environment specified below. The customer or the user of the EPIC diode laser should assure it is used in such an environment.

Emissions Test	Compliance	Electromagnetic environment - guidance
RF emissions CISPR 11	<b>Group 1</b>	The EPIC diode laser uses RF energy only for its internal function. Therefore, its RF emissions are very low and are not likely to cause any interference in nearby electronic equipment.
RF emissions CISPR 11	<b>Class A</b>	The EPIC diode laser is suitable for use in all establishments other than domestic and those directly connected to the public low-voltage power supply network that supplies buildings used for domestic purposes.
Harmonic emissions IEC 61000-3-2	<b>Class A</b>	
Voltage fluctuations/flicker emissions IEC 61000-3-3	<b>Class A</b>	

## GUIDANCE AND MANUFACTURER'S DECLARATION – ELECTROMAGNETIC IMMUNITY

The EPIC diode laser is intended for use in the electromagnetic environment specified below. The customer or the user of the EPIC diode laser should assure that it is used in such an environment.

Immunity test	IEC 60601 test level	Continuous level	Electromagnetic environment - guidance
Electrostatic discharge (ESD) IEC 61000-4-2	± 6 kV contact ± 8kV air	± 6 kV contact ± 8kV air	Floors should be wood, concrete or ceramic tile. If floors are covered with synthetic material, relative humidity should be at least 50%.
Electrical fast transient/burst IEC61000-4-4	± 2 kV for power supply lines  ± 1 kV for input/output lines	± 2 kV for power supply lines  N/A	Main power quality should be that of a typical commercial or hospital environment.  N/A
Surge IEC 61000-4-5	± 1 kV differential mode  ± 2kV common mode	± 1 kV differential mode  ± 2kV common mode	Mains power quality should be that of a typical commercial or hospital environment.
Voltage dips, short interruptions and voltage variations on power supply input lines. IEC 61000-4-11	<5% $U_r$ (>95% dip in UT) for 0.5 cycle  40% $U_r$ (60% dip in UT) for 5 cycles  70% $U_r$ (30% dip in $U_r$ ) for 25 cycles  <5% $U_r$ (>95% dip in $U_r$ ) for 5 seconds	<5% $U_r$ (>95% dip in UT) for 0.5 cycle  40% $U_r$ (60% dip in UT) for 5 cycles  70% $U_r$ (30% dip in $U_r$ ) for 25 cycles  <5% $U_r$ (>95% dip in $U_r$ ) for 5 seconds	Mains power quality should be that of a typical commercial or hospital environment. If the user of the EPIC diode laser requires continued operation during power mains interruptions, it is recommended that the EPIC diode laser be powered from an uninterrupted power supply.
Power frequency (50-60 Hz) magnetic field IEC 61000-4-8	3 A/m	3 A/m	Power frequency magnetic fields should be at levels characteristic of a typical location in a typical commercial or hospital environment.

NOTE:  $U_r$  is the A.C. mains voltage prior to applications of the test level.

**GUIDANCE AND MANUFACTURER’S DECLARATION – ELECTROMAGNETIC IMMUNITY  
(Continued)**

The model EPIC laser is intended for use in the electromagnetic environment specified below. The customer or the user of the model EPIC laser should assure that it is used in such an environment.

Immunity test	IEC 60601 test level	Continuous level	Electromagnetic environment - guidance
Conducted RF IEC 61000-4-6	3 Vrms 150 kHz to 80 GHz	3 V 3Vm	Portable and mobile RF communications equipment should be used no closer to any part of the EPIC diode laser, including cables, than the recommended separation distance calculated from the equation applicable to the frequency of the transmitter.  <b>Recommended separation distance</b>  $d = 1.2\sqrt{P}$  $d = 1.2\sqrt{P}$ 80 MHz to 800 MHz  $d = 2.3\sqrt{P}$ 800MHz to 2.5GHz  Where P is the maximum output power rating of the transmitter in watts (W) according to the transmitter manufacturer and d is the recommended separation distance in meters (m).  Field strengths from fixed RF transmitters, as determined by an electromagnetic site survey, <sup>a</sup> should be less than the compliance level in each frequency range. <sup>b</sup>  Interference may occur in the vicinity of equipment marked with the following symbol:  
Radiated RF IEC61000-4-3	3V/m 80 MHz to 2.5 GHz		

NOTE 1 - At 80 MHz and 800 MHz, the higher frequency range applies.

NOTE 2 -These guidelines may not apply in all situations. Electromagnetic propagation is affected by absorption and reflection from structures, objects, and people.

A. Field strengths from fixed transmitters, such as base stations for radio (cellular/cordless) telephone and land mobile radios, amateur radio, AM and FM radio broadcast and TV broadcast cannot be predicted theoretically with accuracy. To assess the electromagnetic environment due to fixed RF transmitters, an electromagnetic site survey should be considered. If the measured field strength in the location in which the EPIC diode laser is used exceeds the applicable RF compliance level above, the EPIC diode laser should be observed to verify normal operation. If abnormal performance is observed, additional measures may be necessary, such as reorienting or relocating the EPIC diode laser.

B. Over the frequency range 150 kHz to 80 MHz, field strengths should be less than [V1] V/m.

**RECOMMENDED SEPARATION DISTANCES BETWEEN PORTABLE AND MOBILE RF COMMUNICATIONS EQUIPMENT AND THE EPIC DIODE LASER**

The EPIC diode laser is intended for use in an electromagnetic environment in which radiated RF disturbances are controlled. The customer or the user of the EPIC diode laser can help prevent electromagnetic interferences by maintaining a minimum distance between portable and mobile RF communications equipment (transmitters) and the EPIC diode laser as recommended below, according to the maximum output power of the communications equipment.

Rated maximum output power of transmitter W	Separation distance according to frequency of transmitter M		
	150kHz to 80Mhz $d = 1.2\sqrt{P}$	80 MHz to 800 MHz $d = 1.2\sqrt{P}$	800 MHz to 2.5 GHz $d = 2.3\sqrt{P}$
0.01	0.12	0.12	0.23
0.1	0.38	0.38	0.73
1	1.2	1.2	2.3
10	3.8	3.8	7.3
100	12	12	23

For transmitters rated at a maximum output power not listed above, the recommended separation distance  $d$  in meters (m) can be estimated using the equation applicable to the frequency of the transmitter, where  $P$  is the maximum output power rating of the transmitter in watts (W) according to the transmitter manufacturer.

**NOTE 1** – At 80 MHz and 800 MHz, the separation distance for the higher frequency range applies.

**NOTE 2** – These guidelines may not apply in all situations. Electromagnetic propagation is affected by absorption and reflection from structures, objects, and people.

## APPENDIX E - Wireless Equipment Compliance Statement

This statement applies only to the wireless portion of the device:

This equipment has been tested and found to comply with the limits for a Class B digital device, pursuant to part 15 of the FCC Rules. These limits are designed to provide reasonable protection against harmful interference in a residential installation. This equipment generates, uses, and can radiate radio frequency energy and, if not installed and used in accordance with the instructions, may cause harmful interference to radio communications. However, there is no guarantee that interference will not occur in a particular installation. If this equipment does cause harmful interference to radio or television reception, which can be determined by turning the equipment off and on, the user is encouraged to try to correct the interference by one or more of the following measures:

- Reorient or relocate the receiving antenna.
- Increase the separation between the equipment and receiver.
- Connect the equipment into an outlet on a circuit different from that to which the receiver is connected.
- Consult the dealer or an experienced radio/TV technician for help.

**CAUTION: Federal Law restricts this device to sale by or on the order of a dentist or physician or other licensed medical practitioner.**



Conforms to:  
AAMI  
ES60601-1  
IEC60601-1  
IEC60601-2-22  
IEC62366  
IEC80601-2-60  
IEC60825-1  
Certified to:  
CSA C22.2  
No. 60601-1



BIOLASE, Inc.  
4 Cromwell  
Irvine, CA 92618 USA  
949.361.1200  
888.424.6527  
biolase.com



MT Promedt Consulting GmbH  
Altenhofstrasse 80  
D-66386 St. Ingbert/Germany  
+49 6894 581020  
mt-procons.com



**Rx Only.**



**Made in the USA**

©2014 BIOLASE, Inc. All rights reserved. Subject to change without notice.

5400577 Rev B