

User Manual

MELAtherm® 10 Evolution

Washer-Disinfector

from software version 3.0.19



EN

Dear doctor,

We thank you for your confidence demonstrated by the purchase of this MELAG product. As an owner-run and operated family concern founded in 1951, we have a long history of successful specialization in hygiene products for practice-based use. Our focus on innovation, quality and the highest standards of operational reliability has established MELAG as the world's leading manufacturer in the instrument treatment and hygiene field.

You, our customer are justified in your demand for the best products, quality and reliability. Providing "**competence in hygiene**" and "**Quality – made in Germany**", we guarantee that these demands will be met. Our certified quality management system is subject to close monitoring: one instrument to this end is our annual multi-day audit conducted in accordance with ISO 13485. This guarantees that all MELAG products are manufactured and tested in accordance with strict quality criteria.

The MELAG management and team.



Contents

1 General guidelines	5
Symbols used.....	5
Formatting rules	5
Disposal	5
2 Safety.....	6
3 Performance specifications	8
Intended use	8
User benefits.....	8
Program sequence.....	9
Process agents	10
4 Description of the device.....	11
Scope of delivery.....	11
Views of the device	12
Symbols on the device	14
Operating panel and acoustic signal.....	15
Menu structure	18
Water softening unit	19
5 First steps	20
Setup and installation.....	20
Supply with cold water	20
Switching the device on and off	20
Video tutorials	21
MELAconnect App	22
Opening and closing the door	22
Manual door emergency-opening	22
Inserting the basis basket	23
Filling the regenerating salt.....	24
Regenerating the water softening unit	25
Metering process agents.....	25
Holding process agents ready.....	26
Removing air from the metering system	28
6 Cleaning and disinfection.....	29
Type of load	29
Arranging the load.....	29
Reprocessing hollow-body instruments	30
Reprocessing dental transmission instruments.....	31
Reprocessing ophthalmological instruments.....	31
Overview of programs	33
Selecting, starting and following the program	34
Manual program abort.....	35
Authentication and batch approval.....	36
Removing the load after program end.....	40

7 Logging	41
Batch documentation	41
Output media.....	41
Outputting logs immediately and automatically.....	42
Subsequent log output	43
Deleting the saved logs.....	44
Determining the format for the program logs	45
Finding the logs.....	47
8 Settings	48
Menu settings.....	48
Log settings.....	49
Setting the date and time	54
Setting the display brightness	56
Setting the idle mode	56
Setting the volume of the signal tone.....	57
Setting the volume of the key tone.....	57
Connectivity.....	58
Setting the language	59
Setting the water supply.....	59
Setting the water hardness	60
Administrative settings	61
9 Function tests	67
Automatic and manual functional check.....	67
Measuring conductivity.....	67
10 Maintenance	68
Regular checks and cleaning	68
Cleaning on demand	70
Avoiding staining	70
Changing the filter in the drying fan	71
Maintenance.....	72
(Process) Validation	72
11 Pause times	73
Decommissioning.....	73
Transport within the practice	74
12 Malfunctions	75
Displaying events in MELAconnect.....	76
General events.....	76
Warnings.....	78
Malfunction messages	82
13 Technical data	91
14 Accessories and spare parts	93
15 Documentation and approval	94
Glossary	95



1 General guidelines

Please read this user manual carefully before commissioning the device. The user manual includes important safety information. The functionality and value-retention of this device depends on the care accorded to it. Please store these user manual carefully and in close proximity to your device. It represents a component of the product.

Should the user manual no longer be legible, damaged or lost, please obtain a new copy from MELAG. State the device type and your address in an e-mail.

The device type is specified on the type plate on the rear of the device.

Symbols used

Symbol	Explanation
	Indicates a dangerous situation, which if not avoided, could entail slight to life-threatening injuries.
	Draws your attention to a situation, which if not avoided, could result in damage to the instruments, the practice fittings or the device.
	Draws your attention to important information.

Formatting rules

Example	Explanation
see Chapter 2	Reference to another text section within this document.
Universal- Program	Words or phrases appearing on the display of the device are marked as display text.

Disposal

MELAG devices are synonymous with high quality and a long life-span. When you eventually need to decommission your MELAG device, we offer a special disposal service. Simply contact your stockist.

Dispose of accessories and consumption media which you no longer require in the appropriate manner. Comply with all relevant disposal specification in terms of possibly contaminated waste.

The packaging protects the device against transport damage. The packaging materials have been selected for their environmentally-friendly disposability and can be recycled. Returning the packaging to the material flow reduces the amount of waste and saves raw materials. Dispose of all non-required packaging materials at the collection points of the dual system.

Dispose of waste from process agents in accordance with the specifications from the manufacturer of the process agents. Information regarding this topic is provided in the safety data sheets or can be obtained directly from the manufacturer of the process agents.

2 Safety



When operating the device, comply with the following safety instructions as well as those contained in subsequent chapters. Use the device only for the purpose specified in these instructions. Failure to comply with the safety instructions can result in injury and/or damage to the device.

Qualified personnel

- The instrument reprocessing using this washer-disinfector may only be carried out by competent personnel.

Set-up, installation and commissioning

- Check the device for any damage suffered during transport after unpacking.
- The device should only be set-up, installed and commissioned by MELAG authorized technicians.
- The connections for electrical provision and water supply and discharge must be set-up by trained personnel.
- Using the optional electronic leak detector (water stop) minimizes the risk of water damage.
- The device is not suitable for operation in explosive atmospheres.
- Install and operate the device in a frost-free environment.
- The device is conceived for use outside the patient area. The device should be located a minimum of 1.5 m radius away from the treatment area.
- The documentation media (computer, CF card reader etc.) must be placed in such a way that they cannot come into contact with liquids.
- Observe all the information contained in the technical manual during commissioning.

Power cable and power plug

- Comply with all legal requirements and locally-specified connection conditions.
- Never operate the device if the plug or power cable are damaged.
- The power cable or plug should only be replaced by authorized technicians.
- Never damage or alter the power plug or cable.
- Never unplug by pulling on the power cable. Always take a grip on the plug.
- Ensure that the power cable does not become jammed in.
- Never lead the cable along a source of heat.
- Never fix the power cable with sharp objects.
- MELAtherm 10 Evolution DTA is disconnected from the mains via the on-site main switch. MELAtherm 10 Evolution DTB disconnects from the mains by removing the mains plug from the socket.

Daily operation

- Only reprocess instruments designed by their manufacturer for automatic reprocessing in a washer-disinfector. Comply with the instructions issued by the instrument manufacturer in accordance with DIN EN ISO 17664. It is especially important to comply with the information from the instrument manufacturer regarding cleaning instruments for the first time after purchasing new instruments and cleaning them.
- Use only original MELAG accessories or those from other suppliers authorized for use by MELAG.
- When using non-MELAG accessories for the mounting of instruments (especially hollow-body instruments) comply with the manufacturer's information.
- Comply with the specifications of the national standards and directives pertaining to the reprocessing of instruments, the manufacturer's reprocessing instructions and those from the AKI.
- The fore ventilation slits may not be covered.

- Only ever operate the device with the basis basket provided for this purpose.
- Never operate the device unattended. Unsupervised operation of the device can result in damage to the device or your facility and is performed at your own risk. In such a case, MELAG does not accept any liability.

Process agents

- Handle all process agents with care. The cleaning, neutralization and rinsing aids contain irritants and even caustic substances.
- Use process agents suitable for this device. Observe the operating and safety information from the process agent manufacturer. If the process agents have a negative effect on the material of the instruments or the device, the manufacturer of the process agents carries liability.
- The use of process agents not approved by MELAG absolves MELAG of all liability whatsoever for any damage to the device or the instruments.
- Should you have any questions concerning the compatibility of the process agents with the instruments, please consult the manufacturer. MELAG provides information for the application of the process agents in this device, but does not hold any responsibility for their effects on the instruments.
- Any fluids in the drawer and the floor tank underneath can also contain process agents in case of damage. Ensure that you observe the information of the respective process agent manufacturer.

Transport and storage

- During transport and storage, unusual temperatures such as deep frost or extreme heat should be avoided. If this is not guaranteed, the unit must be unpacked and stored at room temperature for at least two hours before installation and commissioning.
- Avoid strong shocks / vibrations.

Maintenance

- Maintenance should only be performed by authorized technicians.
- Maintain the specified servicing intervals.

Malfunctions

- Should the device issue the same malfunction message repeatedly, turn off the device and if necessary, inform your stockist.
- The device may only be serviced by authorized technicians.

3 Performance specifications

Intended use

The MELAtherm 10 Evolution DTA/DTB is intended for use in a medical context such as a clinic or medical and dental practices. EN ISO 15883-1 and 2 defines it as a washer-disinfector intended for reprocessing medical instruments prior to their re-use or a further reprocessing step such as sterilization in a steam sterilizer. You can subject thermostable medical instruments (i.e. instruments which are heat resistant to a temperature of 95 °C) and invasive thermostable instruments to automatic reprocessing as long as they are suitable for this purpose and have been approved for such treatment by their manufacturer. The cleaning is performed using water in combination with a process agent (e.g. MEtherm). Subsequent disinfection is thermal disinfection. This device is not intended to be used in a patient environment.

This device is NOT suitable for the reprocessing of:

- ▶ Thermo-unstable instruments e.g. flexible endoscopes
- ▶ Laboratory waste requiring disposal
- ▶ Crockery
- ▶ Bedpans

User benefits

Universal use

The device both cleans and disinfects. The disinfection phase is conceived so as to reach an A0 value of at least 3000. This kills vegetative bacteria, fungi and their spores and viruses (inc. HBV, HCV) so that the effective range AB is reached in accordance with the specifications of the Robert Koch Institute.

Active drying

The device is equipped with active drying. An integrated drying fan dries the instruments from inside and out after cleaning and disinfection. The additionally fitted HEPA filter guarantees drying with contamination-free air. The automatic reprocessing of hollow-body instruments is also possible. This protects the instruments from stain accretion and rusting. The geometry of some hollow-body instruments mean that they require additional drying.

Automatic filter recognition

The device recognizes before a program start whether the fine sieve has been inserted in the base of the washing chamber. The fine sieve avoids a situation in which instrument components enter the opening of the drain pump or the circulation pump during cleaning, thereby compromising the function of the pumps, rinse arms and the injector rail.

Internal water softening

The device is equipped with an internal water softening unit. The water hardness of the local drinking water is set on the device. The internal water softening unit then automatically adjusts itself to the most suitable performance. This ensures best reprocessing results.

Monitoring the speed of the rinse arms

The rotation speed of the rinse arms is subject to permanent monitoring during a program run. This ensures that the cleaning process proceeds without hindrance and the rinse arms do not become blocked e.g. by protruding instruments in the washing chamber.

Monitoring the rinsing pressure

The rinse pressure is monitored by a pressure sensor during the program run. This ensures an effective cleaning performance. The device aborts a current program if too much foam is generated.

Metering monitoring

The required amounts of cleaning agent and neutralizer are measured out using a hose metering pump. A measurement turbine performs flow monitoring. The rinse aid is metered using a hose pump subject to monitoring for rotation speed.

Drawer for process agents

The drawer for the process agents is located in the lower area of the device in which the cleaning agent, neutralizer and rinse aid containers are stored.

Automatic conductivity measurement

If the device is supplied with DI water in the final rinse, the DI water is subject to automatic internal conductivity measurement.

Manual door emergency-opening

The door can be opened manually in an emergency via the emergency opening following a power outage or malfunction.

Program sequence

The following program steps are indicated on the display during the program run.

Pre-cleaning

Pre-cleaning is performed with cold (min. 22 °C), softened or de-ionized water without process agents. Instrument soiling and contamination (proteins and/or coarse organic deposits) are subject to mechanical cleaning to avoid denaturation from excessively-high water temperatures.

Cleaning

The pre-cleaning is followed by the actual cleaning phase with warm process water and the addition of a mildly-alkaline cleaning agent. As part of the cleaning process, a defined volume of process water is let into the washing chamber and heated to 40 °C. The mildly-alkaline cleaning agent is automatically metered to the process water as soon as the set temperature has been reached.

The process water is heated to 55 °C for the actual cleaning process. This temperature is maintained and any remaining organic deposits will be removed from the instruments.

Neutralization

Main cleaning is followed immediately by neutralization. Neutralization reduces the alkalinity introduced during cleaning and removes acid-soluble deposits such as limescale and extraneous rust etc.

A metered amount of neutralizer is added during this phase. The neutralized process water is subject to continual circulation for a defined period. Finally, the process water is pumped out of the washing chamber completely.

Intermediate rinsing

Intermediate rinsing is the preparatory step for thermal disinfection in which the instruments are rinsed without process agents. The rinsing serves to reduce the residual process agents to a defensible level. In this phase, a metered amount of cold process water is let into the washing chamber and subject to continual circulation for a defined period. Finally, the process water is pumped out of the washing chamber.

Disinfection

The disinfection is performed after intermediate rinsing. The disinfectant effect of MELAtherm is achieved using thermal disinfection and subsequent drying.

A rinse aid is added to the process water at a temperature of 70 °C. The thermal disinfection is performed via continual circulation and heating of the process water to 90 °C and a holding time at this temperature of minimum 5 min. Following the disinfection, the process water is pumped out of the washing chamber completely.

Drying

Drying is effected by drawing ambient air through a class H13 HEPA filter. The instruments are dried inside and out with hot, filtered air. This prevents the development of rust on the instruments.

Displaying the batch counter

The display shows the batch number of the last program run and the total batch counter after every program end or the end of a program abort.

Process agents

**NOTICE**

Only use process agents of the same manufacturer. Process agents from different manufacturers may not be mixed. Any change to another combination may only be performed by trained service technicians. The metering concentration must be adapted to local conditions. This is to be performed by the service technician during set-up in accordance with the manufacturer's information.

**NOTICE**

Observe the operating and safety information from the process agent manufacturer. If, despite observation of the manufacturer's information, the process agents have a negative effect on the material of the instruments or the device, liability lies with the manufacturer of the process agents. The use of process agents not suitable for this device absolves MELAG of all liability whatsoever for any damage to the device or the instruments.

MELAG recommends the usage of Metherm process agents. These are adapted for the process in MELAtherm and achieve excellent cleaning results with optimal instrument protection. Contact the process agent manufacturer when using other process agents. MELAG does not accept liability for the cleaning effectiveness of other process agents in MELAtherm.

Preset metering concentrations

Program	Cleaning agent	Neutralizer	Rinse aid
Universal-Program	6 ml/l	1.5 ml/l	0.3 ml/l
Quick-Program	6 ml/l	1.5 ml/l	0.3 ml/l
Intensive-Program	10 ml/l	1.5 ml/l	0.3 ml/l
Ophthalmic-Program	6 ml/l	1.5 ml/l	-----

When using drinking water (hardness range medium - hard) we recommend the metering concentrations as specified. The metering concentration must be adapted individually depending on the local conditions. The pre-set metering quantities can be used for various combinations of process agents. Observe the metering specifications of the process agent manufacturer. This information can be read-off from the canister in the units "ml/l" or on separate data sheets provided by the manufacturer. The process-relevant parameters must be adapted depending on the nature of the soiling, the quality of the tap water and other framework conditions.

4 Description of the device

Scope of delivery

Please check the scope of delivery before setting up and connecting the device.

Standard scope of delivery

- MELAtherm 10 Evolution Washer-Disinfector
- User manual
- Technical manual
- Record of installation and setting up
- Manufacturer's inspection report and declaration of conformity
- Warranty certificate
- Instructions for the use and care of the accessories
- MELAflash CF card for documentation purposes
- 1 litre storage container for rinse aid
- Filling funnel for the regeneration salt
- Starter package of regeneration salt
- Open-end wrench for the injector rail
- Container tap for 5 litre and 10 litre container
- Wastewater hose with hose clamp Ø 16-25/9

Optionally

- Accessories in accordance with the delivery slip

Views of the device

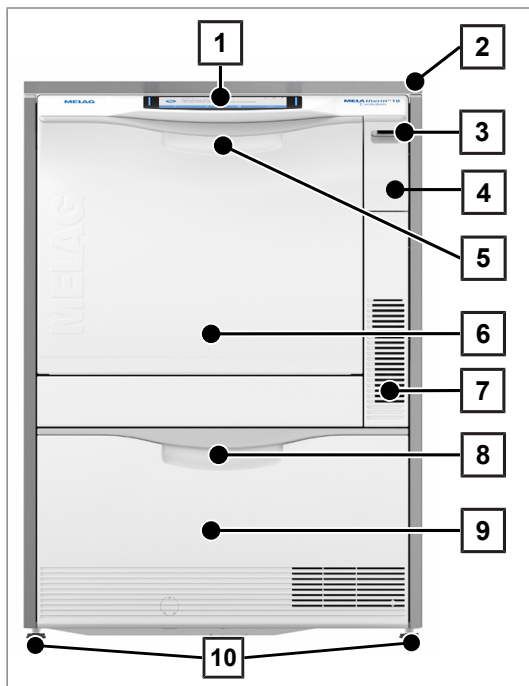

Fig. 1: View from front

- 1 Operating and display panel
- 2 Cover plate (optional)
- 3 Power switch
- 4 Cover cap for CF card slot and Ethernet data connection (for service technician)
- 5 Door handle
- 6 Hinged door, opens forwards
- 7 Ventilation slots for air egress
- 8 Grip for the drawer
- 9 Drawer for process agents
- 10 Device foot

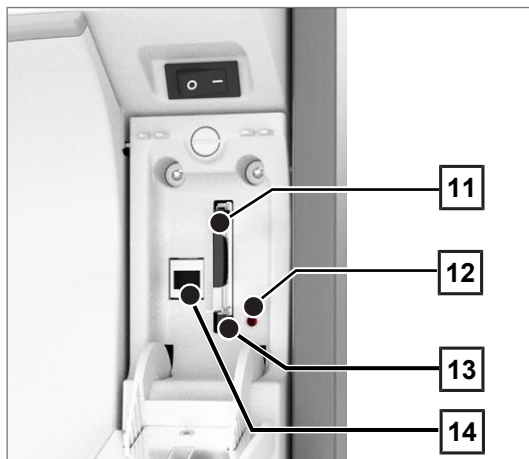

Fig. 2: Cover cap slot open

- 11 Slot
- 12 LED
- 13 Ejection button
- 14 Ethernet data connection

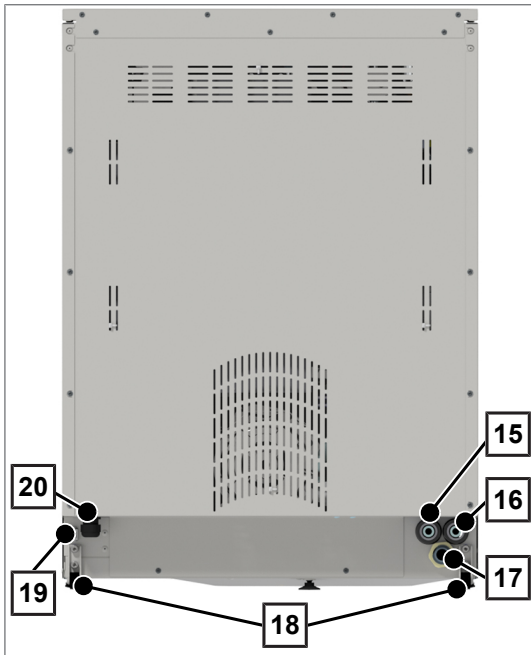

Fig. 3: View from rear

- 15 Demineralized water (DI water) connection
- 16 Cold water connection
- 17 Wastewater connection
- 18 Transport rollers
- 19 Ethernet data connection for permanent network connection
- 20 Mains cable

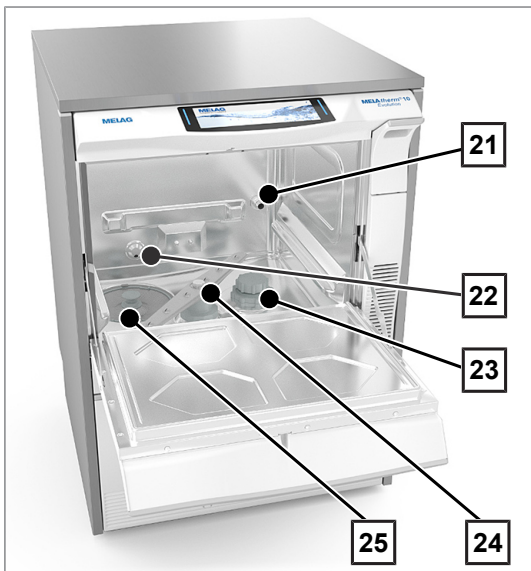

Fig. 4: View inside

- 21 Injector rail connection fitting
- 22 Cold water (CW) inflow and demineralized (DI) water
- 23 Salt container
- 24 Lower rinse arm
- 25 Coarse and fine sieve

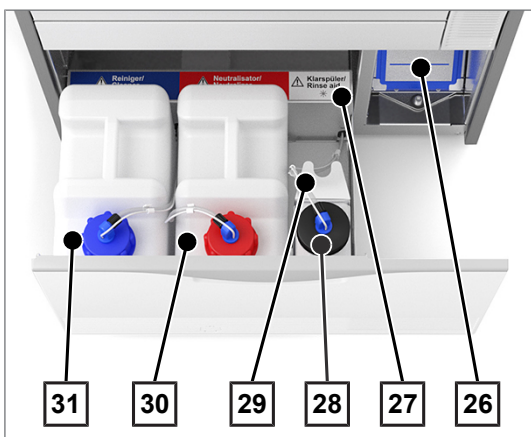

Fig. 5: Process agent drawer open

- 26 Drying fan pre-filter
- 27 Assignment of the process agents
- 28 Container for rinse aid with suction lance
- 29 Suction lance bracket
- 30 Container for neutralizer with suction lance
- 31 Container for cleaning agent with suction lance

Symbols on the device



Manufacturer of the medical device



Date of manufacture of the medical device



Medical device serial number from the manufacturer



Article number of the medical device



Indicates the permitted temperature range (min./max.) of the water supply.



Flow pressure on the water inflow connected from min. to max.



Internal device fuse, rated in amperes [A]



The user manual includes important safety information. Failure to comply with these instructions can result in injury and material damage.



Please read this user manual carefully before commissioning the device.



In affixing this CE mark, the manufacturer declares that this medical product fulfils the basic requirements of the Medical products directive. The four-digit number confirms that this is monitored by an approved certification agency.



The WaterMark certificate is a seal of quality for plumbing and drainage products in Australia and New Zealand.

It confirms that a product meets the requirements of the ABCB (Australian Building Codes Board) and is approved for application.



With the adjacent label, the device manufacturer declares that the medical product corresponds to the basic requirements of the European standard EN 1717 - Protecting Drinking Water from Contamination.



The device may not be disposed as domestic waste. The vendor is responsible for appropriate disposal of the device - it must be delivered to the vendor to be disposed of. MELAG devices are synonymous for long-term quality. When you eventually need to decommission your MELAG device, we offer a special disposal service. Simply contact your stockist.

Operating panel and acoustic signal

Colour touch-display

The operating panel consists of a 7.8 inch touch display.

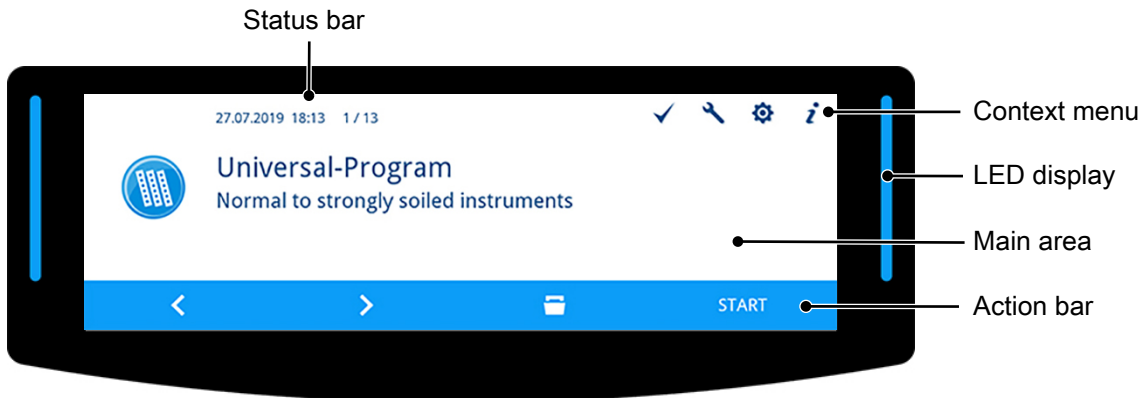

Status bar

The status bar is located on the upper edge of the display.

The date and time are displayed permanently.

The navigation path is displayed on the right-hand side of the time. If the menu has more than one page, the page numbers (e.g. 1 / 13 = page 1 of 13) will also be displayed here.

The serial number of the device and the number (ID) of the event will be displayed following warning and malfunction messages. This is the information that can be transferred to MELAconnect via QR code or which can be transferred manually in the troubleshooting area of the MELAG website, in order to access context-dependent troubleshooting assistance.

Context menu

The context menu displays the submenus, modes and function keys temporarily and in a context-dependent fashion.

Key	Designation	Meaning
	VALIDATION MODE	This key is displayed if the respective program can be run in validation mode. Press this key to change into validation mode. Validation mode can only be run by a service technician with a corresponding PIN.
	MAINTENANCE MODE	This key is displayed if the respective program can be run in maintenance mode. Press this key to navigate to maintenance mode. Maintenance mode can only be run by a service technician with a corresponding PIN.
	SETTINGS	Press this key to navigate to the Settings menu.
	STATUS	Press this key to navigate to the Status menu. Device information and device status information is displayed pertaining to the switching and sensor states.
	LICENCE	This key is displayed in the Status 1 / 14 menu screen. Press this key to access the device licence information.
	DELETE	The key is displayed in the Log output > All logs menu. Press this key to delete all logs in the internal log memory.
	QR CODE	This key is displayed following a malfunction. Press this key to open the auxiliary menu pertaining to the warning and malfunction messages.

LED display and acoustic signals

The LED display to the left and right of the the main area issues a colour to indicate the operating state. An acoustic signal is associated with the colour of the LED display and indicates an expected event.

Colour of the LED	Meaning
Blue	<ul style="list-style-type: none"> ▪ Standby ▪ Readiness after device activation ▪ User action ▪ Program active / video tutorial is running
Green	<ul style="list-style-type: none"> ▪ Program completed successfully ▪ Active drying can be ended early ▪ Measurement successful
Yellow	<ul style="list-style-type: none"> ▪ Instruction (e.g. fill salt or start regeneration) ▪ Warning ▪ Software update active
Red	<ul style="list-style-type: none"> ▪ Malfunction ▪ Program / measurement not successful upon abnormal end ▪ Program / measurement not successful upon user abort



Main area

The left-hand side of the main area displays a symbol with designations for programs, additional programs, logs, program results, messages, menus or PIN-protected areas.

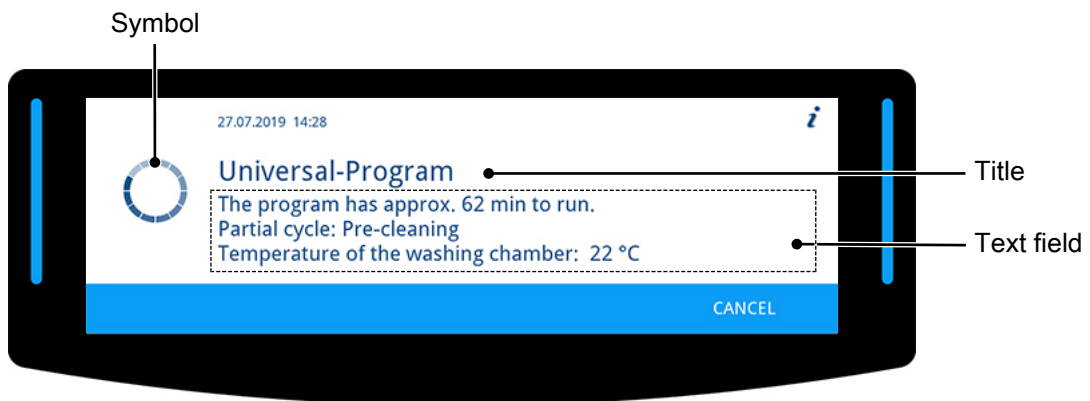







A caption on the right-hand side displays the menu items, values, states of settings or headings of dialogues. The text field is below the caption.



Symbol	Designation	Meaning
	Busy indicator	Independent activities such as a program run, log output or software updates are visualized via animated busy indicator in a clockwise fashion.
	Successful	Symbols designating the program result currently displayed.
	Unsuccessful	
	Notice	Symbols designating the messages currently displayed pertaining to an event or the device status.
	Warning	
	Malfunction	

Symbol	Designation	Meaning
	Documentation	Additional markings that indicate the availability of assistance (e.g. in the user manual, in MELAconnect or on the troubleshooting area in the MELAG website) regarding the issue with which the current message is concerned.
	QR code	

Action bar

Key	Designation	Meaning
	BACK	Press this key to display the previous window or to select a lower parameter.
	FORWARD	Press this key to display the next window or to select a higher parameter.
	LEAVE	Press this key to navigate to the higher-order menu.
	CONFIRM	Press the key to confirm the selection or entry.
	EDIT	Press this key to change the displayed parameter.
	RELEASE	Press this key to unlock the door.
	DETAILS	Press this key to obtain further information.
	SKIP	Press this key to skip steps.
CANCEL	CANCEL	Press this key to abort a running program or process.
OUTPUT	OUTPUT	Press this key to output one or more logs to a selected output medium.
YES	YES	Press this key to accept a query.
NO	NO	Press this key to reject a query.
OK	OK	Press this key to accept information.
START	START	Press this key to start a program, program step, process or a video tutorial.
CONTINUE	CONTINUE	Press this key to start the next process step.

Menu structure

Main menu

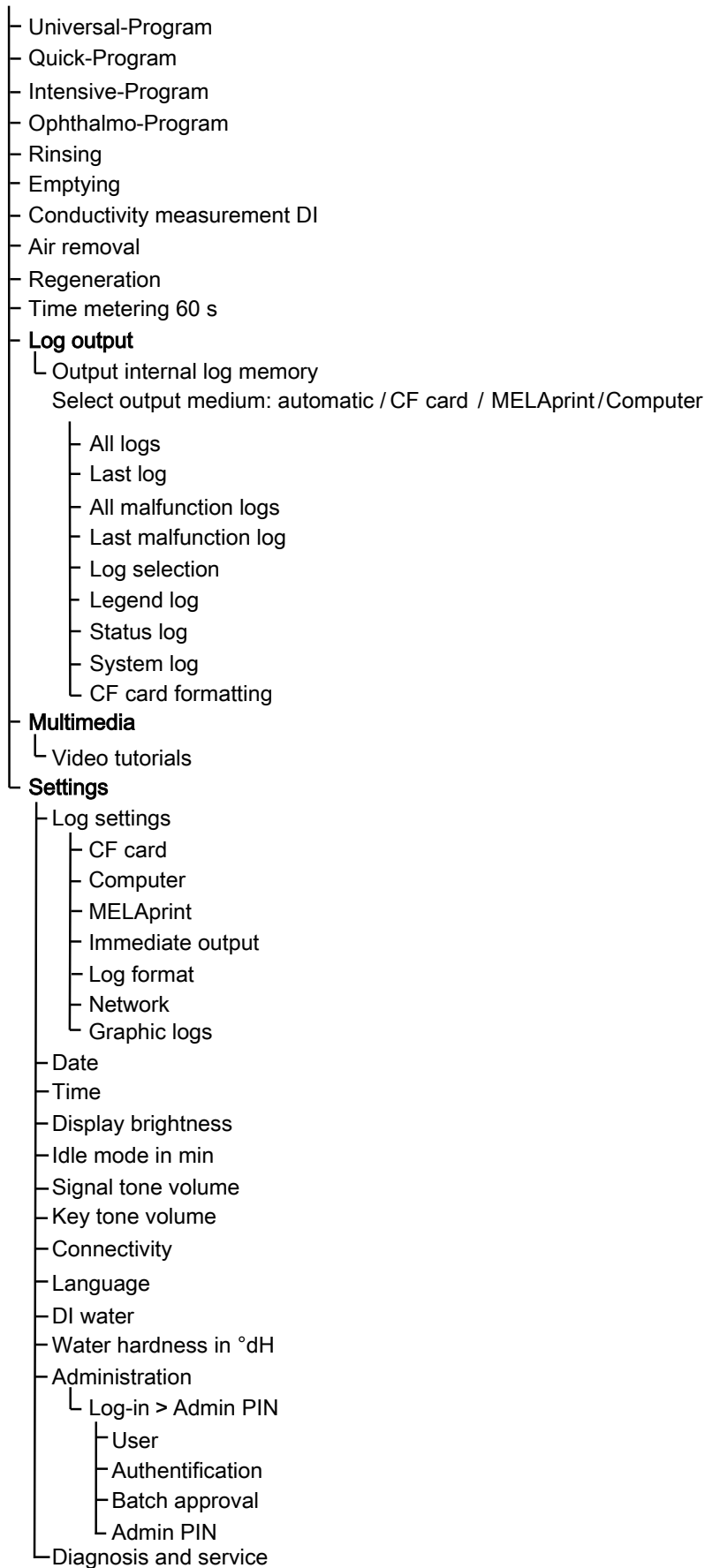

Water softening unit

The tap water is processed in the internal water softening unit to produce an optimal cleaning outcome.

- ▶ Use coarse-grain regeneration salt (NaCl) to regenerate the water softening unit.

Water hardness conversion table

°dH	mmol/l	°f	°e	°dH	mmol/l	°f	°e	°dH	mmol/l	°f	°e
1	0.2	2	2	15	2.7	27	19	28	5.0	50	36
2	0.4	4	3	16	2.9	29	20	29	5.2	52	37
3	0.5	5	4	17	3.1	31	22	30	5.4	54	38
4	0.7	7	5	18	3.2	32	23	31	5.6	56	39
5	0.9	9	7	19	3.4	34	24	32	5.8	58	41
6	1.1	11	8	20	3.6	36	25	33	5.9	59	42
7	1.3	13	9	21	3.8	38	27	34	6.1	61	43
8	1.4	14	10	22	4.0	40	28	35	6.3	63	44
9	1.6	16	12	23	4.1	41	29	36	6.5	65	46
10	1.8	18	13	24	4.3	43	31	37	6.7	67	47
11	2.0	20	14	25	4.5	45	32	38	6.8	68	48
12	2.2	22	15	26	4.7	47	33	39	7.0	70	49
13	2.3	23	17	27	4.9	49	34	40	7.2	72	51
14	2.5	25	18								

5 First steps

Setup and installation



PLEASE NOTE

Comply with the specifications of the technical manual during set-up and installation. This contains all building-side requirements.

Record of installation and setting up

The record of installation and setting up is to be completed by the responsible stockist and a copy sent to MELAG as proof of the correct set-up, installation and initial commissioning. This is a constituent part of any guarantee claim.

Supply with cold water

The reprocessing of medical devices requires the use of drinking water in accordance with the Drinking Water Ordinance or demineralized water (DI water).

The cold water supply is effected either via the in-house connection of the practice or a water treatment unit (e.g. MELAdem 53/53 C).

Increased requirements can be placed on the quality of the DI water (e.g. a low endotoxin content) for the reprocessing of certain medical devices such as ophthalmic instruments. Comply with the following:

- ▶ In such cases, an additional filter system is required for the reprocessing of DI water. Comply with the specifications of the user documentation of your water treatment unit.
- ▶ It is possible that the drinking water has been contaminated by the water installation (domestic installation and pre-device periphery).
- ▶ Arrange for a check of the drinking water quality at the removal point or request a report (e.g. from the building management) before setting up and installing the device.
- ▶ Further information is available from the corresponding trade associations and their publications. In case of uncertainty, contact your stockist or the pertinent professional association.

Switching the device on and off

- ▶ Switch the device on or off at the power switch.



Video tutorials

The **Multimedia** menu contains video tutorials which describe the use of this washer-disinfector in a number of operating situations.

View of the video control



Key	Description	Key	Description
1	Start/Pause	4	Close video
2	Fast forward	5	Volume louder
3	Fast rewind	6	Volume lower

Access a video as follows:

✓ *The device is switched on and the display shows the main menu.*

1. Press the **FORWARD** or **BACK** key repeatedly until the **Multimedia** menu is displayed.

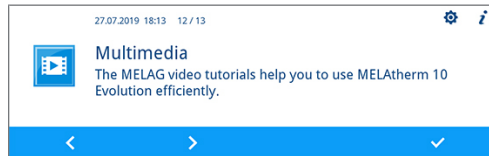

2. Press the **CONFIRM** key to open the menu.
 - ↳ The first tutorial page will be displayed.

3. Press the **FORWARD** or **BACK** key until the desired tutorial window is displayed.

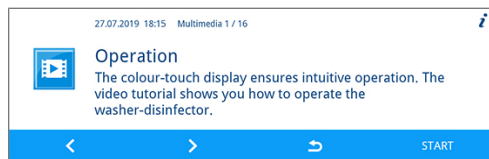

4. Press the **START** key to start the video.



↳ The video started will be played once.

5. Close the video to return to the Multimedia menu.

MELAconnect App

You can use the MELAconnect app from any location in your practice, to access the device status and program progress of the MELAG devices incorporated in your practice network.

MELAconnect provides the following functions:

- Accessing the device status and program progress
- Access to user manuals and video tutorials for using the device
- Locating malfunctions and accessing solutions and assistance immediately
- Performing quick paperless documentation of routine checks of MELAG sealing devices
- Contacting the service technician (contact data must be entered manually)

In order to connect the MELAconnect app with your MELAG device, see the [Connectivity](#) [▶ page 58] section.

Opening and closing the door

A motor closes the door automatically. For this reason, it is important that the device is connected to the power supply and is switched on. The door unlocks automatically after a successful program run. The door cannot be opened following a power outage. In such a case, activate [Manual door emergency-opening](#) [▶ page 22].



PLEASE NOTE

The door can only be opened during a program run using a program abort.

The door will be unlocked after the program abort has been acknowledged and sufficient cooling has been performed.

Opening the door

1. Switch on the device at the power switch.
2. Press the **RELEASE** key to unlock the door.
3. Open the door forwards.

Closing the door

- ▶ Close the door and press it until the motorized lock sets in.

Manual door emergency-opening



WARNING

Danger of contamination from insufficient disinfection

A program aborted by emergency opening is classed as not having been performed. Process water can remain in the washing chamber; the instruments have not been disinfected completely.

- The instruments must be subject to renewed reprocessing.



CAUTION

Danger of scalding from hot steam.

Hot steam could be released upon opening the door.

- Never operate the emergency door opening mechanism during an active program.
- Wear suitable protective clothes.

Proceed as follows to perform emergency door opening:

1. Pull out the process agent drawer.
 - An emergency opening grip is located in the front left-hand side of the device.
2. Pull down on the grip until you hear a clicking sound.

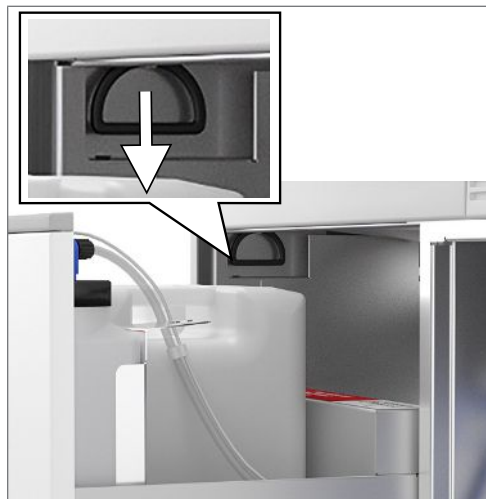

3. Pull the door forwards strongly using the grip.

Inserting the basis basket

A port for the connection of the injector rail is located on the right-hand rear side of the washing chamber of the washer-disinfector.

- ▶ Slide the basis basket with the injector rail opening into the washing chamber until it connects to the port.



Filling the regenerating salt



CAUTION

Danger of injury from insufficient protective measures!

Performing work without first taking the corresponding protective measures can result in injuries.

- Comply with the working safety measures required by the respective tasks.



NOTICE

Malfunctions of the water softening unit from unsuitable regenerating salt.

Fine grain regeneration salt can cause device malfunctions. We do not recommend the use of pellets, as the salt dissolves too slowly.

- Use only special, coarse grain regeneration salt (additive-free NaCl).
- Never use cooking salt, table salt, de-icing salt, cattle salt or road salt. These salts usually contain insoluble components.
- Never pour cleaning agent or other process agents in the salt container.

Filling the regenerating salt for the first time (by the service technician upon initial commissioning)

1. Fill enough water in the salt container **once** until it overflows. This enables dissolution of the salt.
 - ↳ No further water is required for all subsequent salt fillings.
2. Fill the salt container with 1 kg regenerating salt.
 - ↳ The device can only be operated if the salt container contains sufficient regenerating salt.

Re-filling the regenerating salt

Insufficient regenerating salt or its absence will result in the display of the corresponding display notification.

- If the display shows **"There is almost no regeneration salt left. Re-fill the regenerating salt soon."**, you can perform up to ten washing runs depending on the program selected and the hardness of the water.
- If the display shows **"The regenerating salt is exhausted. Re-fill the regenerating salt."**, you must refill with regenerating salt immediately. Otherwise you will be unable to start a further program.

You can refill the regenerating salt at any time without the corresponding display notification. After filling, work manually to start the additional "Rinsing" program in order to rinse away any brine or salt residue from the washing chamber.

In order to refill the regeneration salt, proceed as follows:

1. Acknowledge the display message **"There is almost no regeneration salt left. Re-fill the regenerating salt soon."** using the **CONFIRM** key.
2. Open the door.
3. Remove the basis basket.

4. Open the lid of the salt container by turning it anti-clockwise.

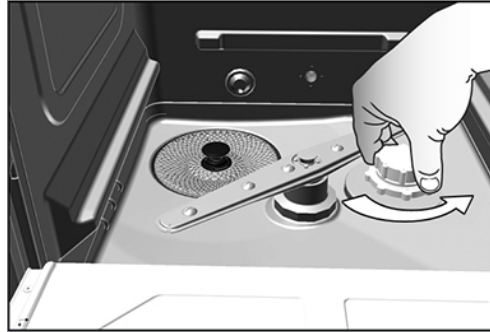

5. Insert the filling funnel for the regenerating salt in the opening.
6. Fill the salt container with regenerating salt using the filling funnel.

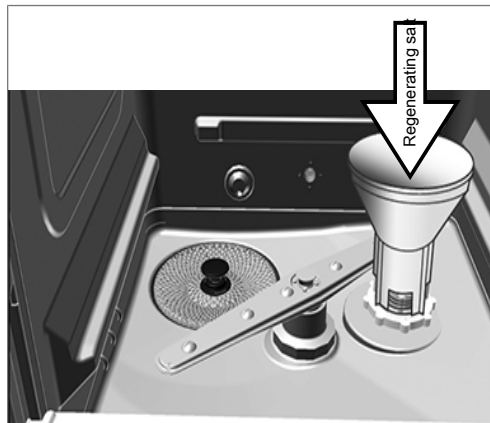

7. Clean the edge of the filling opening of salt residue.
8. Remove the filling funnel and screw on the lid of the salt container.
9. Insert the basis basket.
10. Wait three minutes and then start the "Rinsing" program without (instrument) load.

Regenerating the water softening unit

The internal water softening unit regenerates automatically in certain intervals. The program run time is extended by a number of minutes. You can regenerate the water softening unit manually after e.g. having filled it with salt without a warning having previously been issued.

- ▶ To do so, start the "Regeneration" program.

Metering process agents

The concentration of the process agents is set once during the initial device setup performed by the services technician (see technical manual). During a program run, the preset concentration of the relevant process agents is metered automatically.

Holding process agents ready



WARNING

Danger of acid burns by irritant substances!

Improper handling of the process agents may cause caustic burns and health damage.

- Protect your eyes, hands, clothing and all surfaces from contact with the process agents.
- Comply with the information from the manufacturer of the process agents.
- Every type of fluid (e.g. in the drawer, in the device floor tank or fluid emerging from the device) issued from the device as the result of damage could potentially contain aggressive process agents.



NOTICE

Damage to instruments and the device from unsuitable process agents!

- Use only those process agents approved by MELAG for use in this device.
- Comply with the information from the process agent manufacturer.

An absence or insufficient filling level of a certain process agent means will trigger the display of the corresponding display message. In this case you must replace or refill the process agents container.

Comply with the following provisions pertaining to the use of the process agents:

- ▶ When re-filling, please use the same process agents, set on the device during installation (see the tie-on label on the container in the process agent drawer).
- ▶ Changing the combination of process agents may only be performed by a qualified and trained technician.
- ▶ Every change of a process agent in a validated device necessitates revalidation.
- ▶ Use a citric acid based neutralizer for the reprocessing of dental transmission instruments.
- ▶ Use mild alkali cleaning agents on material, hygienic and ecological grounds.
- ▶ Check that your instruments are compatible for use with rinse aid.
- ▶ All air should be removed from the metering hoses before commissioning or after changing a container, see [Removing air from the metering system](#) [▶ page 28].

Containers for process agents

Every process agent has its own container and a suction lance with screw-on lid:

- Cleaning agent: 5 l container with a blue suction lance screw-on lid
- Neutralizer: 5 l container with a red suction lance screw-on lid
- Rinse aid: 1 l container with a black suction lance screw-on lid

- ▶ Place the container in the drawer in accordance with the process agent assignment. A container can only be closed correctly if the colour of the process agent matches that of the suction lance screw-on lid.

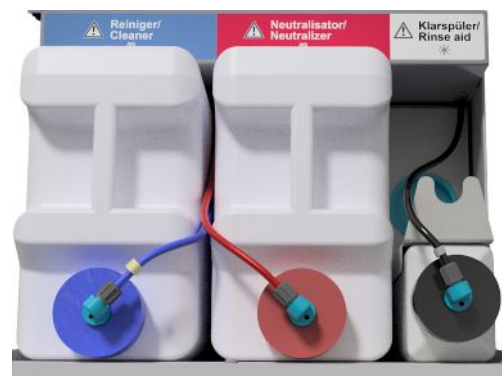

Change the containers for cleaning agent and neutralizer

1. Unscrew the suction lance from the container and place it in the suction lance bracket.

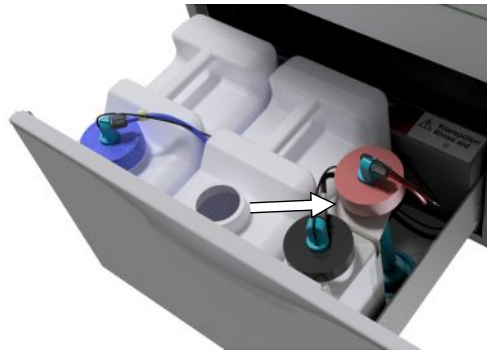

2. Place the new container in the process agents drawer and screw on the suction lance.

➔ The screw-on lid of the suction lance points forwards.

3. Remove the air from the metering system, see [Removing air from the metering system](#) [▶ page 28].

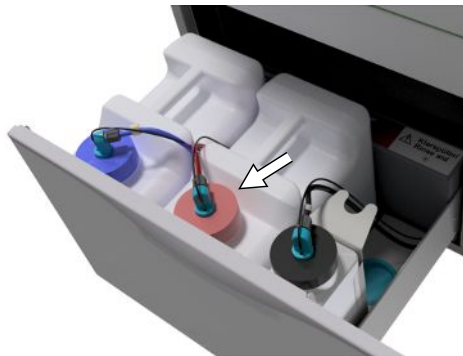

Refilling rinse aid



PLEASE NOTE

Rinse aid may not be used to reprocess ophthalmological instruments, see [Reprocessing ophthalmological instruments](#) [▶ page 31].



PLEASE NOTE

A streaky instrument surface could be caused by too much rinse aid.

Proceed as follows to fill an empty container with rinse aid:

1. Unscrew the suction lance from the container and place it the suction lance bracket behind it.

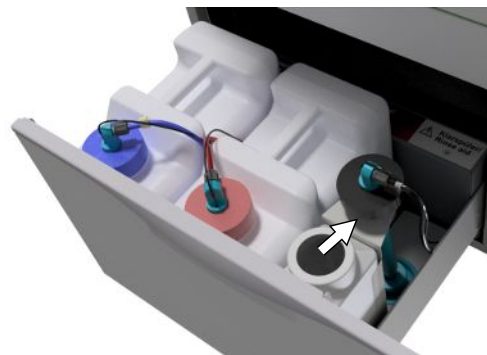

2. Transfer the rinse aid from the original packaging into the MELAG container.
 - ↳ Use the container tap (for 5 l and 10 l container) included in the scope of delivery for ease of filling.
 - ↳ Fill the container with rinse aid $\frac{3}{4}$ full, otherwise the rinse aid will overflow during insertion of the suction lance.
3. Screw the suction lance onto the container.
4. Remove the air from the metering system, see [Removing air from the metering system](#) [▶ page 28].

Removing air from the metering system

The metering system must be vented after filling the containers, performing a product change or removing the suction lances. Air removal removes all air pockets from the hoses and ensures good metering.

- ✓ *The rinse aid suction lance not used for ophthalmic instruments must be inserted head-first in the suction lance bracket during the running of the "Air removal" program.*
- ✓ *The "Air removal" program must be started twice after initial filling of the container.*

1. When reprocessing ophthalmic instruments, insert the suction lance of the non-used rinse aid head-first in the suction lance bracket **before the program start**.

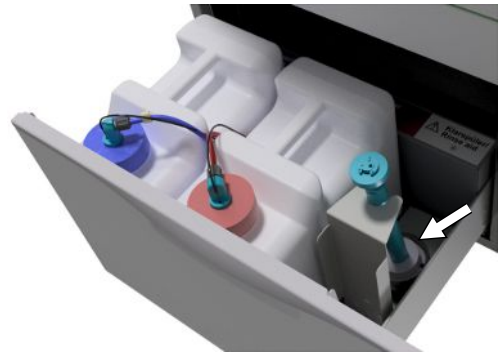

2. Press the **FORWARD** or **BACK** key repeatedly until the "Air removal" program is displayed.

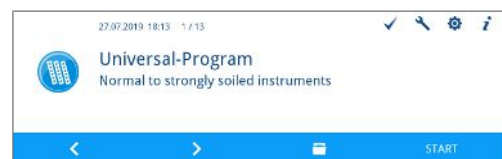

3. Press the **START** key to start the "Air removal" program.



6 Cleaning and disinfection

Type of load

Comply with the specifications of the document *Instructions for the use and care of the accessories* when loading the device. Only use the loading pattern specified and approved within the scope of the validation. This device can clean and disinfect max. 10 kg of the following type of load:

- massive instruments,
- hollow-body instruments e.g. aspirator tips, which are fixed to injector nozzles or
- transmission instruments e.g. handpieces by using the adapter.

Further accessories may be required when **reprocessing ophthalmological instruments** (not available from MELAG). The operator is responsible for validating the procedure in combination with special load accessories. It is especially important that lines to hollow-body instruments are maintained without kinking and as short as possible.

Arranging the load



CAUTION

Danger of injury from sharp and pointed instruments.

Using inappropriate procedures to load the device with sharp and pointed instruments can result in injuries. Baskets and sieve cassettes with wire meshes or other openings do not provide any protection against penetration by sharp instruments.

- Wear protective gloves.
 - Proceed with caution when sorting sharp and pointed instruments.
 - Arrange sharp and pointed instruments in such a way as to prevent the danger of injury.
-



NOTICE

Only reprocess instruments designed by their manufacturer for automatic reprocessing in a washer-disinfector.

- Some brands are only authorized for thermal disinfection after a specific year of manufacture.
 - Comply with the information from the relevant instrument manufacturer.
-

The basis basket must be inserted with insert racks, instrument baskets, wash trays and/or sieve cassettes in order to arrange the load. The basis basket with an injector rail is available for reprocessing hollow-body instruments.

Further accessories and their user instructions such as insert racks for wash trays, sieve cassettes and instrument baskets etc. are listed in the document *Instructions for the use and care of the accessories*.

Comply with the following specifications when arranging the load:

- ▶ Empty all residual liquids from containers before arranging them in the device. Rinse away any liquids (e.g. disinfectant solutions) thoroughly.
- ▶ Never place any individual instruments directly in the basis basket. Use baskets or trays to this end.
- ▶ Ensure that instruments do not protrude from the sides of the instrument basket or the basis basket. Protruding instruments can damage the seal and the surface of the door or the side walls of the washing chamber. The instruments can break.
- ▶ Place hollow-body instruments in the device in such a way as to ensure safe flushing. If necessary, use the accessories developed especially for the reprocessing of hollow-body instruments such as injector nozzles, Luer connections, adapters etc. See the *Instructions for the use and care of accessories*.

- ▶ Avoid blockages of the rinse arm from instruments protruding upwards or downwards. The rinse arms must be able to rotate freely.
- ▶ Avoid spray shadow. A good cleaning outcome depends on the correct arrangement of the instruments.
- ▶ Arrange all objects resembling containers such as kidney basins etc. with their opening pointing downwards.
- ▶ Place components with openings or compressions at an angle, so that the water can run off them.
- ▶ Only use thermostable instruments approved by their manufacturer for reprocessing.

Reprocessing hollow-body instruments



WARNING

Danger of contamination from insufficient disinfection

Residue on the hollow-body instruments can hinder water pass through and thus impair their disinfection.

- Check the hollow-body instrument for free passage before reprocessing.



PLEASE NOTE

All openings must be connected to an accessory piece when using a multi-way distributor or the injector rail. Only then can a correct function be guaranteed.

- Seal non-used openings.



PLEASE NOTE

Use a filter insert for hollow-body instruments with an inside diameter ≤ 0.8 mm.

- Do not use the metal filter disc or the Cleanfinity Filter in the ophthalmic area.
- Instead, use the ceramic filter disc or the plastic central filter.

Comply with the following specifications before automatic reprocessing:

- ▶ Flush all hollow-body instruments after use with patients / before automatic reprocessing.
- ▶ Reprocess only those hollow-body instruments which guarantee sufficient and reproducible rinsing. Remove instruments with a recognisably reduced throughflow.
- ▶ Use only MELAG adapters (accessories list) for the injector rail to reprocess hollow-body instruments. The suitability of the hollow-body instruments for the respective adapter and the sufficient flushing of the instruments can only be proven by validation.
- ▶ Check the connection between the adapter and the hollow-body instrument for stability both before and after reprocessing. Should a connection work loose after reprocessing, the instruments must be reprocessed again.
- ▶ Comply with the cleaning and replacement intervals when using filter inserts. The cleaning and replacement intervals are listed in the separate document *Instructions for the use and care of the accessories*.
- ▶ When reprocessing dental and ophthalmologic transmission instruments, comply with the specifications of the special reprocessing instructions in chapter [Reprocessing dental transmission instruments](#) [▶ page 31] and [Reprocessing ophthalmological instruments](#) [▶ page 31].

Rules for the use of filters / filter discs:

Diameter of the inner lumen	Use of a filter
≤ 0.8 mm	Filter required e.g. a triple distributor with a filter disc
> 0.8 mm	No filter required, direct connection of the adapter to the injector rail possible

Reprocessing dental transmission instruments

Comply with the following specifications before automatic reprocessing:

- ▶ The exterior surfaces of the handpieces should be free of all residue e.g. dental cement.
- ▶ The air and spray channels must be entirely clear.
- ▶ Avoid the drying-on of soiling, especially on the handpieces.
- ▶ Use a citric acid based neutralizer for reprocessing dental transmission instruments.
- ▶ In case of any residual moisture after reprocessing, e.g. after a drying abort, dry hollow-body instruments with medical compressed air.

Care of the instruments and adapters

Dry the spray / air / water channels immediately after the successful cleaning and disinfection using clean (medical) compressed air and then maintenance with suitable maintenance and care products and oils.

The adapter for handpieces should be checked for dirt at regular intervals. Clean the individual adapter components under running water where necessary. The silicon inserts can be rubbed with a damp, non-fuzzing cloth.

Reprocessing ophthalmological instruments

Please comply with national recommendations for the cleaning of medical products under the aspect of reprocessing of infectious prion proteins (CJD).



WARNING

Danger of contamination from biological interactions.

Devices used to reprocess ophthalmologic instruments may only be used exclusively for this purpose.

- Do not reprocess any instruments used in retinal surgery (coming into contact with retinal tissue, subretinal fluid and the optical nerve).
- Fit these devices with a suitable filter system e.g the ceramic filter disc or the plastic central filter.
- Do not use the metal filter disc or the Cleanfinity Filter for the reprocessing of ophthalmological instruments.



NOTICE

Only reprocess instruments designed by their manufacturer for automatic reprocessing in a washer-disinfector.

- Some brands are only authorized for thermal disinfection after a specific year of manufacture.
- Comply with the information from the relevant instrument manufacturer.



NOTICE

Do not use a rinse aid to reprocess ophthalmological instruments.

1. If present, remove the rinse aid container from the process agents drawer and hang the black suction lance in the suction lance bracket so that the cover is positioned at the top.

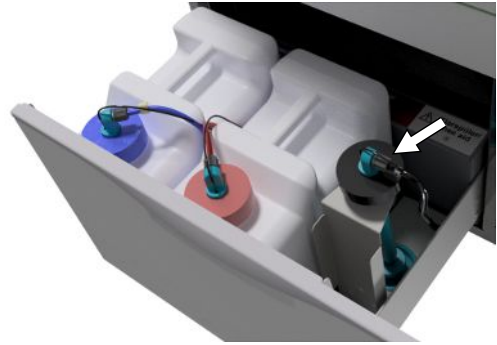

2. The suction lance only needs to be placed head-first in the suction lance bracket if the metering hoses are to be bled, see [Removing air from the metering system](#) [▶ page 28].



PLEASE NOTE

Use demineralized water to reprocess ophthalmological instruments.

- To this end, e.g. connect a mixed-bed resin cartridge.

Suitable program

Reprocess ophthalmological instruments in the Ophthalmo-Program. Only this program enables monitoring of the water conductivity during the disinfection phase; this ensures a residual conductivity which is non-critical for applications on the human eye.

Comply with the following specifications before automatic reprocessing:

- ▶ Cleaning should be done using a mildly-alkaline cleaning agent. Neutralization should be done using a citric acid based neutralizer.
- ▶ Flush all hollow-body instrument after use with patients / before automatic reprocessing with DI water.
- ▶ Reprocess only those hollow-body instruments which guarantee sufficient and reproducible rinsing. Remove instruments with a recognisably reduced throughflow.
- ▶ All hollow-body instruments should be connected with the rinse bar designed for the purpose.
- ▶ Ensure that plugs and/or cables from phaco handpieces are not able to slip through the basis basket, otherwise the rinse arm can become blocked.
- ▶ Try to prevent dirt from drying or encrusting on and in the instruments.
- ▶ Dry any residual moisture, e.g. after a drying abort or hollow-body instrument after reprocessing, with medical compressed air.
- ▶ When using the rinsing system, individual outlets which are not connected can be sealed with suitable accessories.

Instrument care

Comply with the manufacturer's instructions regarding the care and maintenance of the instruments / the load accessories.

Routine controls





Perform a routine check of the pH value after reprocessing hollow-body instruments.

1. Blow through the hollow-body instruments with medical compressed air onto indicator paper (e.g. from Macherey-Nagel: PEHANON pH 4.0-9.0). The measurement accuracy must amount to or exceed 0.5.
2. Compare the value displayed on the indicator paper with the pH value of the final rinse water from the previous performance qualification.
3. Should you discover any deviations, contact the customer services.







Overview of programs

- ▶ Select the program according to the level of soiling of the load. Comply with the specifications from the validation.
- ▶ The Universal-Program is sufficient for every-day general cleaning and disinfection. The Quick-Program is designed for lightly soiled instruments.

The following table lists the correct program for each load.

Program	Symbol	Nature of the instruments / degree of soiling	Operating time ^{*)} without drying time	
			DTA	DTB
Universal-Program ¹⁾		<ul style="list-style-type: none"> For normal to strongly soiled instruments 	42 min	63 min
Quick-Program		<ul style="list-style-type: none"> For unsoiled or lightly soiled instruments 	37 min	57 min
Intensive-Program		<ul style="list-style-type: none"> For especially heavily soiled instruments Like the Universal-Program but with a longer cleaning time 	54 min	67 min
Ophthalmology-Program		<ul style="list-style-type: none"> For ophthalmological instruments Like the Universal-Program, but with a longer cleaning time, double intermediate rinsing without subsequent rinse aid 	43 min	63 min

^{*)} The specified operating times are average values and apply to the recommended running water pressure at a cold water temperature of 15 °C.

Additional program	Symbol	Application	Operating time ^{*)}
Rinsing		<ul style="list-style-type: none"> For rinsing strongly soiled instruments (e.g. blood). A disinfection program must then be started. To rinse out the washing chamber after adding salt; without process agents, no disinfection. 	3 min
Emptying		<ul style="list-style-type: none"> Pumping out residual water from the washing chamber 	1 min
Conductivity measurement DI		<ul style="list-style-type: none"> For measuring the conductivity of the DI water 	2 min
Air removal		<ul style="list-style-type: none"> After filling / changing the process agents, i.e. product change etc. With decommissioning and commissioning 	5 min
Regeneration		<ul style="list-style-type: none"> Regenerating the internal water softening unit 	8 min
Time metering 60 s		<ul style="list-style-type: none"> Only for service technicians 	--

^{*)} The specified operating times are average values and apply to the recommended running water pressure at a cold water temperature of 15 °C.

¹⁾ In accordance with the A0 concept from EN ISO 15883-1 thermal disinfection is performed with 90 °C (+5 °C, -0 °C) as standard and an application time of 5 min (min. A0-3000).

Selecting, starting and following the program



NOTICE

Unsupervised operation of the device can result in damage to the device or your facility. In such a case, MELAG does not accept any liability.

- Never operate the device unattended. Unattended operation is performed at the operator's risk.

Ensure compliance with the following prerequisites in order to secure the optimal cleaning performance before every program start:

- ▶ The process agents containers are sufficiently full.
- ▶ The injector rail nozzles / adapter are clean.
- ▶ The rinse arms can be turned freely.
- ▶ The load is arranged correctly.
- ▶ Baskets and inserts are inserted correctly.

Selecting and starting a program:

1. Select a program in accordance with the [program overview](#) [▶ page 33].
2. Use the **FORWARD** or **BACK** key to navigate to the desired program.

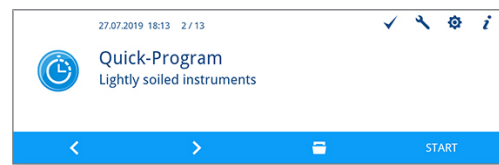

↪ The display shows the program names and the type of reprocessing for which the program is suitable.

3. Start the selected program by pressing the **START** key.

Following the program run on the computer

You can follow the current progress of a program run on every computer in the (practice) network. To do so, an IP address must be issued for the device and it must be incorporated in the (practice) network.

1. Open a web browser window in the practice computer (we recommend Mozilla Firefox or Internet Explorer / Microsoft Edge).
2. Enter the device IP address in the address bar of the web server, e.g. 192.168.72.206 and confirm with enter.

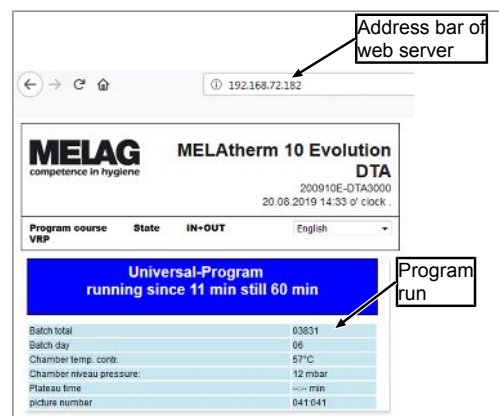

↪ The program run and the device information such as e.g. serial number and device software version will be displayed.

Manual program abort



NOTICE

Cancellation of a current program by deactivation at the power switch may cause damage at the device.

- Never abort a program by switching off at the power switch.

Abort the program during drying



WARNING

Nucleation because of poor drying.

If a program is aborted during drying, residual dampness can remain on the instruments.

- Only abort a current program in exceptional reasons.
- Dry the instruments manually.



CAUTION

Danger of burns from hot instruments and surfaces.

The instruments and chamber can remain hot even after the device has been switched off.

- Allow the device to cool before removing the instruments.
- Wear suitable protective gloves.

If a program is aborted during drying, the program is classed as having been ended successfully. Proceed as follows to abort the program during drying:

- Wait until the display shows **Partial cycle: Drying**.
- Press the **CANCEL** key and confirm the abort with the **YES** key.
- Press the **RELEASE** key to open the door.

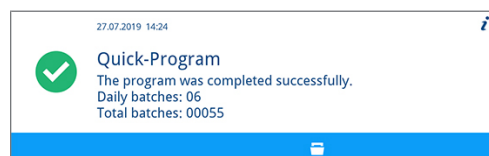
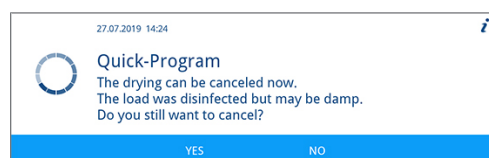
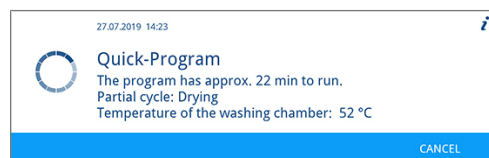

Aborting the program before the start of drying



WARNING

Danger of infection from program abort.

If a program is interrupted before the start of a drying phase, the load is taken as not having been cleaned and disinfected. This endangers the health of the patient and the practice team.

- Only abort a current program in exceptional reasons.
- Never open the door after a program start.
- Reprocess the instruments again after a program abort.



CAUTION

Danger of burns from hot instruments and surfaces.

The instruments and chamber can remain hot even after the device has been switched off.

- Allow the device to cool before removing the instruments.
- Wear suitable protective gloves.

To abort a program before drying, press the **CANCEL** key and follow the instructions on the display.

Authentication and batch approval

Authentication

This function records the identity of the person who removed the load from the device with or without subsequent batch approval. If authentication has been activated and the reprocessing program completed successfully, you will automatically be asked to enter your user PIN. Your user ID will be specified in the log.

Batch approval

The batch approval following program end is used to evaluate and log the outcome of the reprocessing (batch approved/not approved). The user will apply various criteria to evaluate the batch (e.g. degree of cleaning and drying, position of the load etc.).

The batch approval function (with or without authentication) must be activated to perform it. You will be automatically requested to perform batch approval after successful completion of the reprocessing program.

Batch assessment and approval with authentication

Once the reprocessing program has been completed successfully, you will automatically be asked to evaluate the batch and provide it with approval.

Proceed as follows to perform batch assessment with authentication:

- ✓ *Authentication has been activated, see [Authentication](#) [▶ page 64].*
- ✓ *Batch approval has been activated, see [Batch approval](#) [▶ page 65].*
- ✓ *The reprocessing program has been completed successfully.*

1. Press the **RELEASE** key.

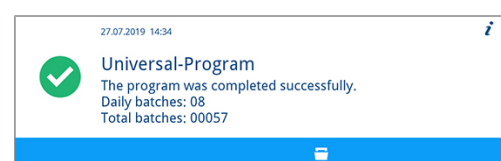

➔ The **User PIN** window will be displayed.

2. Enter your four-digit user PIN and press the **CONFIRM** key.

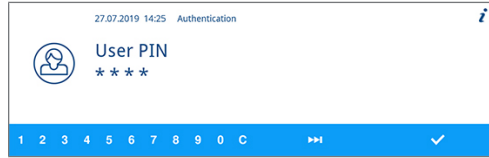

- ↳ The door will be unlocked.
- ↳ The **Approve batch** window will be displayed.

3. Press the **DETAILS** key to obtain **Assessment criteria for batch approval**.

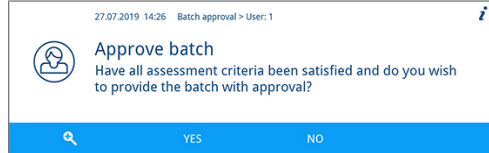

4. Press the **FORWARD** key and read the assessment criteria carefully. Check the reprocessing batch using the assessment criteria outlined.

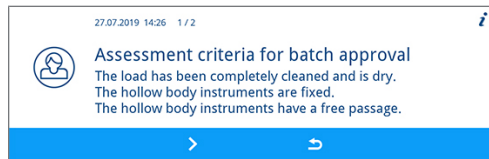

5. Press the **LEAVE** key to return to the **Approve batch** window.



6. Press the **YES** key, if the assessment criteria have been fulfilled.

Press the **NO** key, if the assessment criteria have not been fulfilled.

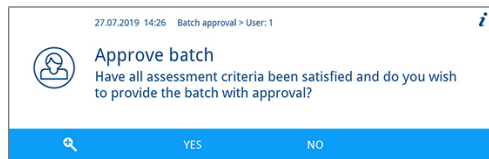

- ↳ The log states **User ID: ##** and **Approve batch: YES OR NO**.

Batch assessment and approval without authentication

Batch assessment can only be performed without authentication if batch approval is activated and authentication has been deactivated. If this is the case, you will be requested to enter your user PIN before batch assessment.

Proceed as follows to perform the batch assessment without authentication:

- ✓ *Authentication has been deactivated, see [Authentication](#) [▶ page 64].*
- ✓ *Batch approval has been activated, see [Batch approval](#) [▶ page 65].*
- ✓ *The reprocessing program has been completed successfully.*

1. Press the **RELEASE** key.

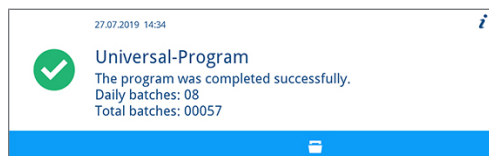

- ↳ The **Approve batch** window will be displayed.

2. Press the **DETAILS** key to obtain **Assessment criteria for batch approval**.
3. Press the **FORWARD** key and read the assessment criteria carefully. Check the reprocessed batch using the assessment criteria outlined.
4. Press the **LEAVE** key to return to the **Approve batch** window.
5. Press the **YES** key, if the assessment criteria have been fulfilled.
Press the **NO** key, if the assessment criteria have not been fulfilled.

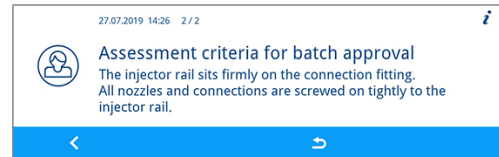
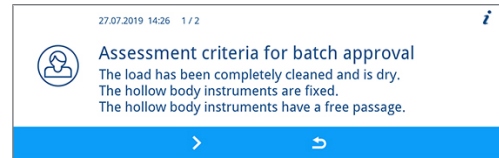

➔ The log states **User ID: Deactivated** and **Approve batch: YES OR NO**.

Authentication without batch approval

If you do not require an automatically documented batch assessment and approval, you can perform authenticated removal of the load. In this case, the fact of the reprocessed load having been removed by an authenticated user will be documented.

Proceed as follows to perform authenticated removal of the load:

- ✓ *Authentication has been activated, see [Authentication](#) [▶ page 64].*
- ✓ *Batch approval has been deactivated, see [Batch approval](#) [▶ page 65].*
- ✓ *The reprocessing program has been completed successfully.*

1. Press the **RELEASE** key.

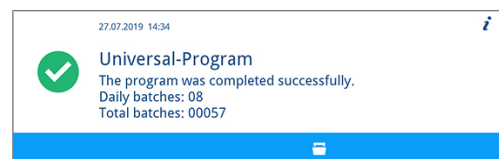

➔ The **User PIN** will be displayed.

2. Enter your four-digit user PIN and press the **CONFIRM** key.



➔ The door will be unlocked and can be opened.

➔ The log states **User ID: ##** and **Approve batch: Deactivated**.

Skip authentication

If both batch approval and authentication have been activated, you will automatically be requested to evaluate the batch and provide it with approval after the reprocessing program has been completed successfully. You can skip authentication and proceed in the process.



PLEASE NOTE

Skipping authentication means that the batch will automatically be evaluated as not having been approved.

You can document the assessment separately and continue in the prescribed practice process.

Proceed as follows to skip authentication:

- ✓ *Authentication has been activated, see [Authentication](#) [▶ page 64].*
- ✓ *Batch approval has been activated, see [Batch approval](#) [▶ page 65].*
- ✓ *The reprocessing program has been completed successfully.*

1. Press the **RELEASE** key.

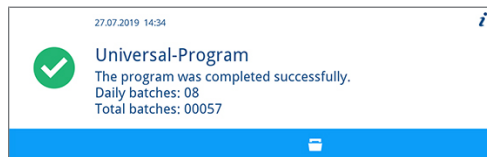

↳ The **User PIN** window will be displayed.

2. Press the **SKIP** key.

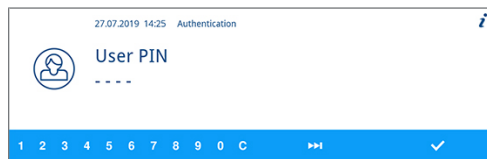

↳ The security query **Skip authentication** will be displayed.

3. Press the **YES** key.

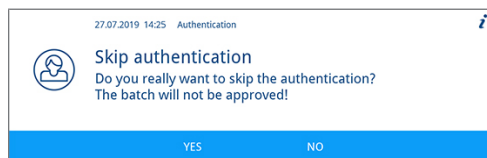

↳ The door will be unlocked.

↳ The **Door unlocked** window will be displayed.

4. Open the door.

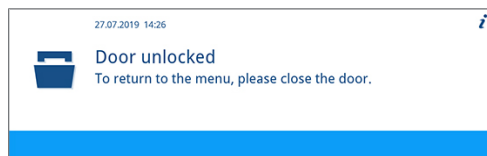

↳ The log states **User ID: Skipped** and **Approve batch: NO**.

Removing the load after program end



CAUTION

Danger of burns from hot instruments and surfaces.

The instruments and chamber can remain hot even after the device has been switched off.

- Allow the device to cool before removing the instruments.
- Wear suitable protective gloves.



NOTICE

Soiling can become encrusted even after a rinsing program; this could result in instrument corrosion.

- Remove the instruments from the washing chamber after every program run.
- Do NOT leave the instruments in the washing chamber overnight.



PLEASE NOTE

Open the door immediately after the end of the program to prevent the accretion of condensation.



PLEASE NOTE

Dry the hollow-body instruments with clean (medical) compressed air after reprocessing in order to remove any residual moisture.

The display message indicates whether and when a program has ended successfully. The display shows the batch number of the last program run and the total batch counter after every program end or the end of a program abort.

1. Press the **RELEASE** key and open the door.

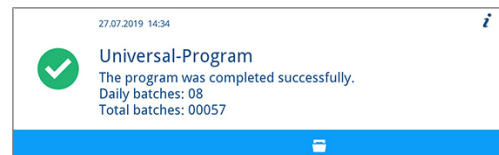

2. Remove the load whilst complying with all the hygiene and working safety regulations.

The load is only classed as having been cleaned and disinfected if all the following points have been met. Otherwise, reprocess the load afresh.

- ▶ The program has been performed without interruption or malfunction.
- ▶ Instruments must be completely clean and dry.
- ▶ Hollow-body instruments are fixed.
- ▶ The interior of the hollow-body instruments are accessible.
- ▶ The injector rail still sits snugly on the connection tube in the washing chamber.
- ▶ The nozzles and connections to the basis basket are tight.

7 Logging

Batch documentation

The batch documentation serves as proof of the successful conclusion of the program and represents an obligatory part of quality assurance (MPBetreibV). The device internal log memory saves such data as the program type, batch and process parameters of all the programs completed.

To obtain the batch documentation, you can output the internal log memory and transfer its data to various output media. This can be performed immediately at the end of every program or at a later point, such as at the end of the day.

As delivered, the MELAflash CF card is set as the logging medium. Setting a different output medium or activating the internal log memory is outlined under [Settings](#) [▶ page 48].

Capacity of the internal log memory

The device is equipped with an internal log memory. This saves all the data regarding the program automatically. The capacity of the internal log memory is sufficient for 15-20 logs. If the internal log memory is full, the display will show **The internal log memory is full. Please output all logs via Log output in the main menu.** If this warning is issued, provide the specified output medium (see [Settings](#) [▶ page 48]) and output the affected log (see [Log settings](#) [▶ page 49]). If the program is continued, the logs are deleted automatically; the last ten saved logs remain in the log memory.

MELAG recommends outputting logs immediately.

Output media

You can output the logs of the finished programs via the following output media:

- MELAflash CF card
- A computer via the (practice) network (LAN)
- MELAprint 42/44 log printer with network adapter

The output media can be combined in any fashion. Thus it is possible both to save logs on the CF card (included in the scope of delivery) and also to print them on the log printer.



PLEASE NOTE

Further information about the log printer (e.g. the duration of the readability of the log print-out) is specified in the appendant operating manual.

Using the CF card as an output medium



NOTICE

Premature removal of the CF card from the card slot or its inappropriate handling can result in data loss, damage to the CF card, the device and/or its software.

- Never push the CF card in the slot with force.
 - Never remove the CF card from the slot whilst it is being written or read. The red LED next to the card slot on the right will illuminate in short irregular intervals during reading and writing access.
 - Hold the CF card cover cap closed during operation so that the CF card ejection button is not actuated by mistake.
-

Inserting the CF card

The card slot for the CF card is located behind the cover cap on the right, adjacent to the door below the power switch. When inserting the CF card in the slot, ensure that it is aligned correctly.

1. Open the CF card cover cap.
2. Insert the CF card in the slot with the contacts at the front. The MELAG logo on the CF card points towards the LED.



3. Slide the CF card in the card slot until it clicks. Do not use force. When the CF card has been placed correctly, the red LED will illuminate shortly.
4. Close the cover cap.

Removing the CF card

1. Open the CF card cover cap.
2. Press the ejection button and remove the CF card.
3. Close the cover cap.

Using the computer as an output medium

You can either connect a computer directly to a device or via a network if the following conditions are fulfilled:

- ▶ The computer is fitted with a network card with a RJ45 bushing (LAN).
- ▶ An FTP server or an FTP service is installed on the computer (when the log is issued via FTP).
- ▶ A suitable program, e.g. MELAtrace/MELAviView, is installed (when the log is issued via TCP).

Working in the **Settings** menu, you can perform or change network settings, see section [Log settings](#) [▶ page 49].

Outputting logs immediately and automatically

In its delivery state, the MELAflash CF card is set on the device as the output medium in the **Settings** menu. As such, automatic output of logs after program end (immediate output = **yes**) is activated. Log output on multiple activated media is performed successively. You can select or add an alternative output medium for automatic log output, or add a further output medium, see [Log settings](#) [▶ page 49].

Text logs

The following requirements must be fulfilled in order to output text logs immediately after the end of a program:

- ▶ In the **Settings > Log settings > Immediate output** is set to **yes**.

- ▶ In the **Settings > Log settings >** a minimum of one output medium has been selected and **Immediate output** has been set to **yes**.
- ▶ The activated output medium is available (e.g. the MELAprint 42/44 log printer or CF card).

Graphic logs (optional)

The following requirements must be fulfilled in order to record graphic logs:

- ▶ In the **Settings > Log settings > Graphic logs** at least one output medium is set to **yes**.
- ▶ At least one of the output media selected for graphic logs corresponds to an output medium for the text log. This means that at least the computer or the CF card must be activated as an output medium for both log types.
- ▶ The selected output medium has been connected.



PLEASE NOTE

Graphic logs cannot be saved in the internal log memory and cannot be outputted via the log printer MELAprint 42/44.

- Save the graphic log on the CF card or the computer.

Comply with the following specifications for automatic log output:

- ▶ The text log is transferred to the selected output medium after the end of the program run. At the same time, this text log is saved in the internal log memory and marked as “outputted”.
- ▶ If multiple output media have been activated, all activated output media must be connected to the device. Otherwise, the text logs are saved in the internal memory and are classed as “not outputted”.
- ▶ If the internal log memory is almost full, the device will register all the text logs which are classed as “not outputted”. The warning 386 appears after the program start. You can acknowledge this warning with the **CONFIRM** key and continue with the program run.
- ▶ With warning 372, logs not yet outputted must be outputted manually. Only then is a program start possible. The log memory is deleted automatically after manual issue; the last ten logs remain in the log memory. The manual outputting of logs is described here: [Subsequent log output](#) [▶ page 43].

Subsequent log output

The **Log output** menu provides the option of deleting and outputting logs subsequently independently of the time of the program end. Proceed as follows:

1. Working in the main menu, press the **FORWARD** or **BACK** key until the **Log output** menu is displayed.

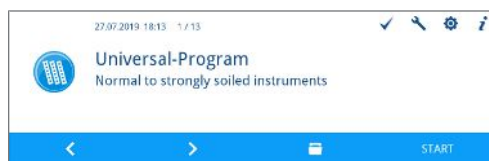

2. Press the **CONFIRM** key to open the menu.

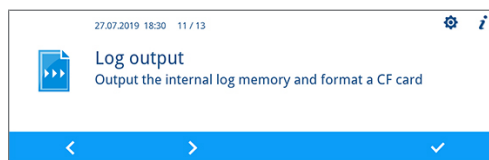

3. Press the **FORWARD** key until the desired output medium (CF card, MELAprint, Computer, automatic) is displayed.



Should you wish to accept the settings from the **Log settings** menu, select the output medium **automatic**.

4. Press the **CONFIRM** key to select the displayed output medium.

5. Press the **FORWARD** key, until the desired log type e.g. **Last log**, **All malfunction logs** etc. is displayed.
6. Press the **OUTPUT** key to start log output.

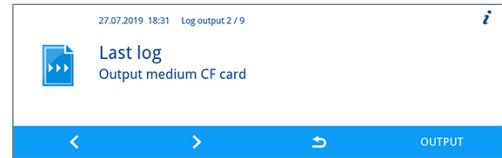

Deleting the saved logs

Proceed as follows to delete the saved logs:

1. Save the log on an output medium before deleting it.
2. Working in the main menu, press the **FORWARD** or **BACK** key until the **Log output** menu is displayed.
3. Press the **CONFIRM** key to open the menu.
4. Press the **CONFIRM** key again.
5. If necessary, press the **FORWARD** or **BACK** key until the **All logs** window is displayed.
6. Working in the context menu, press the **DELETE** key.

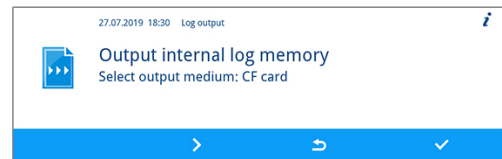
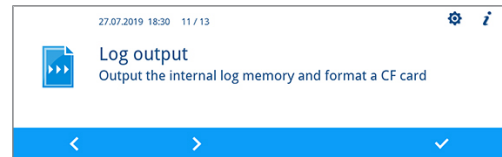
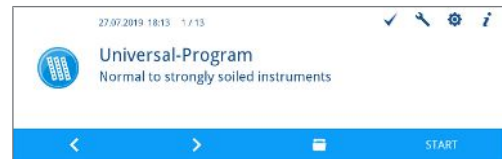

↪ A security query is displayed: **Delete all internal log memory logs?**

7. Press the **YES** key to delete all logs.

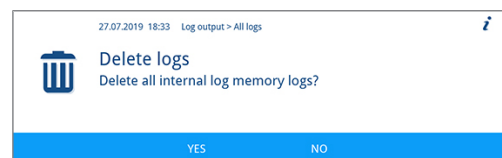
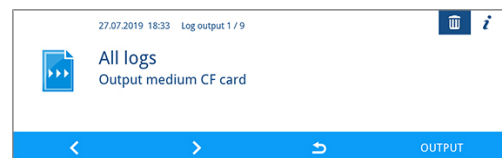

Determining the format for the program logs

The log format enables you to determine which of the data saved in the log memory is to be outputted. You can choose between the formats **0**, **1** and **2**. The log format **2** is the standard format. Working in the **Settings** menu, you can select the log format for the program log (see [Log settings](#) ▶ page 49).

You can choose between the following format:

Format	Description
0	Short log: Only the log header is outputted.
1	Short log with program steps: The log header and the program steps are outputted.
2	Standard log: In addition to the log header and the program steps, a legend is displayed explaining the individual program steps. Logs outputted via the MELAprint log printer always contain a legend row located under the row to which it refers.

Log types

In addition to logs for successfully completed programs, there are other types of log. These can also be outputted via the selection list in the **Log output** menu. You can identify the log type by the ending of its file name.

Ending	Stands for	Explanation
.PRO	Program log	Log of a successfully completed program
.GPD	Graphic log	A log in which the processes are recorded graphically
.STR	Malfunction log	Log of an aborted program
.STB	Malfunction in standby	Log with malfunctions without a program having run
.LOG	System log	List of all the malfunctions and changes to the system in order of time (log book)
.STA	Status log	Summary of all the important settings and system states (counter, measured values etc.) + a list of all process-relevant parameters (VRP)
.LEG	Legend log	Contains all step abbreviations used in the program log
.DEM	Demo log	Log of a program simulated as completed in DEMO mode (only for presentation purposes)
.DES	Demo malfunction	Log of a program simulated as interrupted (presentation)

Example of a program log for a successfully completed program

```

-----
10 MELAG MELAtherm 10 Evolution DTA
-----
15 Program : Universal-Program
20 TARGET °C min
21 Pre-clean: 22.0 03:30
23 Cleaning: 55.0 10:00
28 Desinfect: 90.0 05:00
30 Date : 19.07.2019
35 Batch : Day:10 Total:00071
36 User ID: 1
37 Batch approved: Yes
=====
40 Program successfully completed
=====
50 ACTUAL °C +/- K min
51 Pre-clean: 26.9 +1.0/-1.0 03:30
53 Cleaning: 57.5 +0.3/-0.2 10:00
58 Desinfect: 92.2 +0.2/-0.2 05:00 4152
-----
60 Conduct.: 7.2 (---) µS/cm
65 Start : 12:27:59
70 End time : 13:35:26 (67:27 min)
=====
80 SN:201910E-DTA0104
=====
81 Firmware : V3.013 18.07.2019
82 Parameter: V3.010 26.06.2019
83 BO : V3.524 24.05.2019
85 Release : V3.0.15 25.06.2019
-----
Step Start End Time °C ml mbar
--> Process start
S1X01 0:00 0:00 0:00 36.8 ---- -- 01 Start01
--> Pre-cleaning
...
--> Cleaning
--> Neutralization
--> Intermediate rinsing

--> Disinfection
--> Drying
--> Process end
E1Z01 67:18 67:27 0:09 37.8 ---- -- 51 End01
-----
>> Never change code in following row <<
0100002C1B4802BE0306064C0B3C0AD0130D9610
07BD3EFECA15229618881B257A98850427217323
930815C1C892292E3965C071864442576F5F38AC
648A82A3945A3D404141440157A94648AE494AEC
>> Proof of authenticity batch log <<
-----
Voltage max/min: 225/214
CW:33.0 DI: 7.0
0.0 0.0 -0.00 0.0
--et1--et2---eps-----etu-----END

```

```

-----
10 Log header: Device name
-----
15 Program name
20 Column heading for 21-28
21 Nominal value temperature and holding time
23 Nominal value temperature and holding time
28 Nominal value temperature and holding time
30 Date
35 Daily and total batch counter
36 User ID and authentication
37 Status batch approval
=====
40 Control message
=====
50 Column heading for 51-58
51 Nom. value temp. range and holding time
53 Nom. value temp. range and holding time
58 Nominal value temp. conditions, A0 value
-----
60 DI water conductivity for final rinse
65 Time at program start
70 Time at program end
=====
80 Device serial number
=====
81 Installed firmware version
82 Installed parameter version
83 Installed user interface
85 Approval version
-----
Step = Program step
Start = Time at start of partial cycle
Ende = Time at end of partial cycle
Time = Time (mm:ss), required by a partial cycle
°C = Temperature of the rinse liquor in the
washing chamber in degrees Celsius
ml = Quantity of cold water and DI water,
respective process agent consumed during a
program step
mbar = Rinse pressure
92 = Up to five warnings
95 = Event number upon program abort
-----
Proof of authenticity:
Must never be changed; permits inference that
the data was created on a MELAG device and
has not been changed.

-----
Sensor measurement values are displayed
following a malfunction. The values are helpfu
for a service technician.

```

Finding the logs



PLEASE NOTE

Do not rename the directories, otherwise logs will be stored in both the renamed directory as well as the device directory which the device generates automatically.

All memory media (CF card or computer) contain a directory with the encoded serial number of the device concerned following log output. The directory name consists of five characters identical with the first five characters of every log, e.g. CR0ZH. This directory contains sub-directories with the month of log generation e.g. 01_2020 for January 2020. This contains all logs generated by the device in this month. The device directory is entered in the main directory on the CF card.



The device checks the memory medium after every type of log output (immediate output after a completed cycle or the transfer of multiple logs simultaneously). Should a directory not exist, it automatically creates a directory for the device and the month. If logs are outputted on the same memory medium more than once, a "duplicate" directory will be created under the device directory in which these logs will be saved only once.

Given direct log transfer to a computer, set the memory location in the program (FCP, FTP) used on your computer.

8 Settings

Menu settings

In the **Settings** menu you can set parameters such as the date, time or display brightness.

The following sequence describes general steps for performing settings.

1. Working in the main menu, press the **FORWARD** or **BACK** key until the **Settings** menu is displayed.

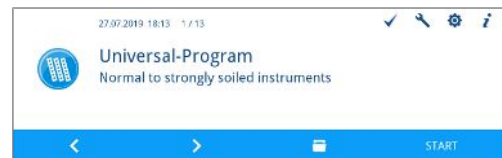

2. Press the **CONFIRM** key to open the **Settings** menu.

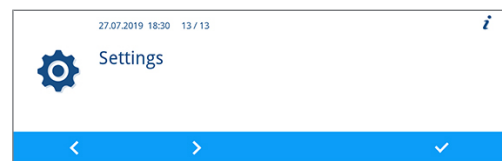

3. Working in the context menu, press the **FORWARD** or **BACK** key until the desired submenu or the parameter to be changes (e.g. display brightness) is displayed.

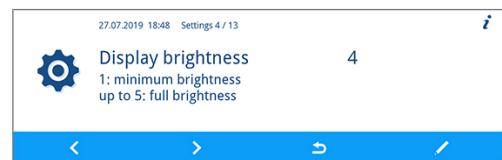

4. Press the **EDIT** key.

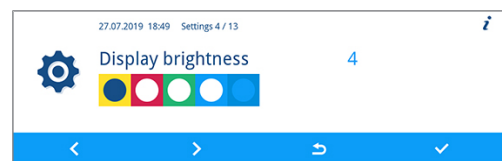

➔ The parameter is displayed bright blue. You can make or change settings.

5. Press the **FORWARD** or **BACK** key to increase or reduce the displayed parameters.

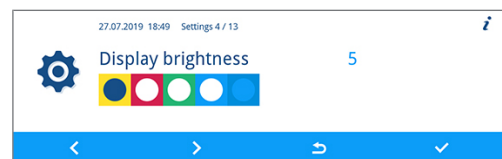

6. Press the **CONFIRM** key to accept the setting.



➔ The parameter is displayed dark blue.

7. Press the **LEAVE** key.

8. Press the **YES** key to leave the **Settings** menu.

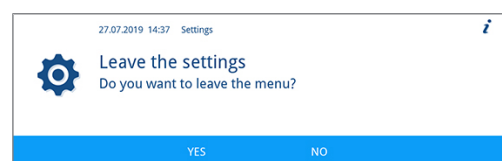

- Press the **YES** key to save the settings.
Press the **NO** key to discard the settings.

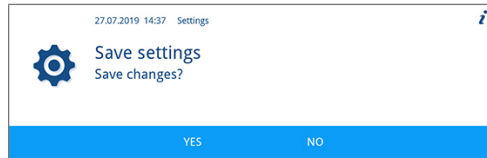

PLEASE NOTE

Not all the settings made are saved immediately and automatically, but only upon leaving the **Settings** menu.

Pressing the **YES** key, saves the settings.

Pressing the **NO** key means that the settings are not saved.

Some settings require a system restart. The restart is performed automatically after saving the settings.

Log settings

You can perform log settings for automatic logging working in the **Log settings** submenu. Detailed information regarding logging is provided here: [Logging](#) [▶ page 41].

Open the **Log settings** submenu as follows:

- Open the **Settings** menu, see [Menu settings](#) [▶ page 48].

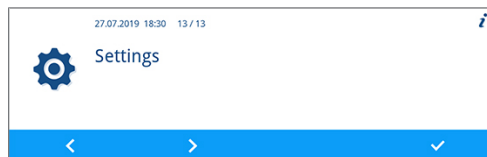

- Working in the menu, press the **FORWARD** or **BACK** key until the **Log settings** is displayed.

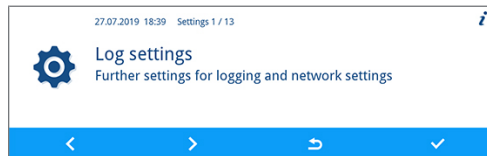

- Press the **CONFIRM** key to open the submenu.

Selecting the output medium

Working in the **Log settings** submenu you can select the output media for automatic logging.

The following example describes how to select a CF card as an output medium. The selection of a different or a further output medium is performed in accordance with the same procedure.

Proceed as follows to select the output medium:

✓ *The **Settings** > **Log settings** menu is open.*

- If necessary, working in the **Log settings** submenu, press the **FORWARD** or **BACK** key until the **CF card** window is displayed.

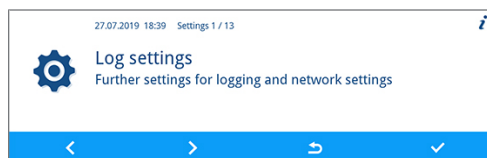

- The **yes** parameter indicates that logs are to be saved automatically on the CF card.

Press the **EDIT** key, if this parameter is to be changed.

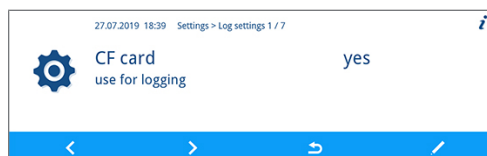

3. Press the **FORWARD** or **BACK** key to navigate between **yes** and **no**.

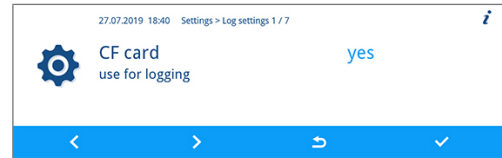

4. Press the **CONFIRM** key to accept the change.

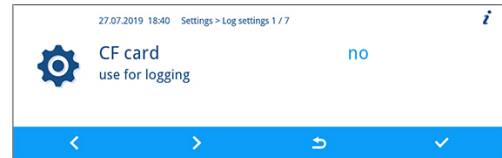

Immediate output

If you have set an output medium for logging, immediate output must also be activated. If immediate output is not active, then none of the output media pre-determined for automatic logging will be used.

Proceed as follows to set the immediate output:

✓ *The Settings > Log settings menu is open.*

1. Working in the **Log settings** submenu, press the **FORWARD** or **BACK** key until the **Immediate output** window is displayed.

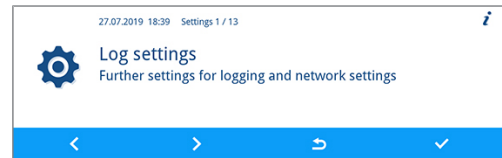

2. Press the **EDIT** key, if this parameter is to be changed.



3. Press the **FORWARD** or **BACK** key to navigate between **yes** and **no**.



4. Press the **CONFIRM** key to accept the change.



Determining log format

Proceed as follows to set the log format:

✓ *The Settings > Log settings menu is open.*

1. Working in the **Log settings** menu, press the **FORWARD** or **BACK** key until the **Log format** is displayed.

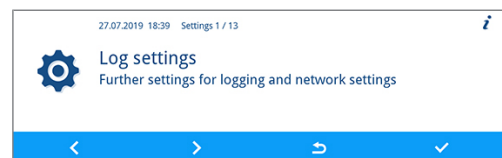

2. Press the **EDIT** key, if this parameter is to be changed.

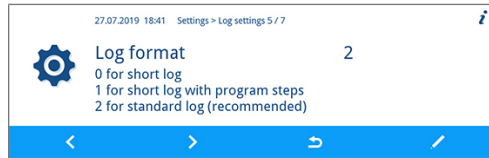

3. Press the **FORWARD** or **BACK** key to navigate between the formats **0**, **1** and **2**.

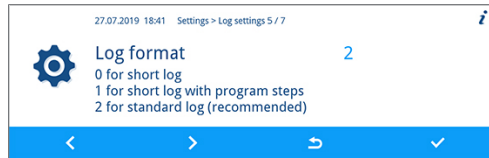

4. Press the **CONFIRM** key to accept the change.

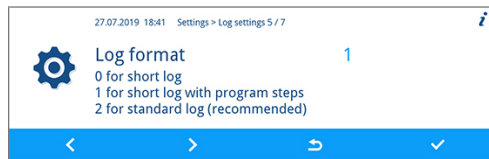

For comprehensive information regarding the log formats **0**, **1** and **2**, see [Determining the format for the program logs](#) [▶ page 45].

Setting the network



NOTICE

The setting up in the (practice) network will require in-depth understanding of the network technology.

Handling errors of IP addresses can result in malfunctions and data loss in your user network.

- IP addresses may only be set by the (practice) network system administrator.

You can change the network settings for logging by working in the **Network** submenu.

Open the **Network** submenu as follows:

✓ *The Settings > Log settings menu is open.*

1. Working in the **Log settings** menu, press the **FORWARD** or **BACK** key until the **Network** window is displayed.

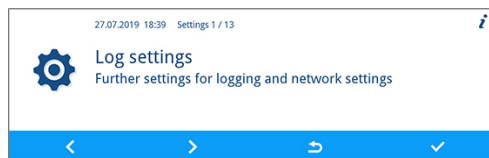

2. Press the **CONFIRM** key.



➔ You can make settings for MELAtherm-IP, the connection type, the FTP password, the TCP port, the computer IP, the MELAprint IP, the gateway IP and the subnet mask.

MELAtherm IP, computer IP, MELAprint IP, gateway IP, subnet mask

This example demonstrates how to set the MELAtherm IP. The computer IP, MELAprint IP, gateway IP or subnet mask are set in the same fashion.

✓ *The Settings > Log settings > Network menu is open.*

1. Working in the **Network** submenu, press the **FORWARD** or **BACK** key until the **MELAtherm IP** window is displayed.

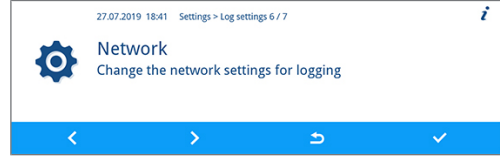

2. Press the **CONFIRM** key, if you wish to perform a change.



3. Press the **FORWARD** or **BACK** key to select the digit to be changed. An open arrow on the left next to the digit indicates the figure currently selected.

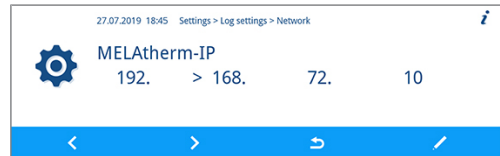

4. Press the **EDIT** key.

5. Press the **FORWARD** or **BACK** key to change the digit.

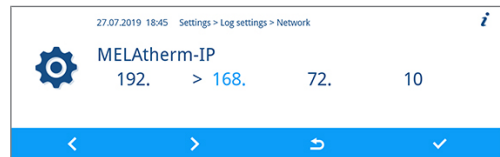

PLEASE NOTE

Holding the **FORWARD** or **BACK** key pressed accelerates the increase or decrease.

6. Press the **CONFIRM** key to accept the change.

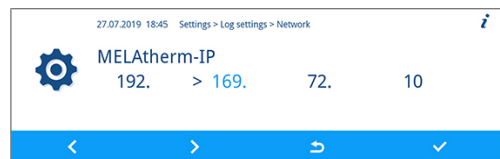

7. Repeat steps 3 to 6, to change further digits of the IP.

Type of connection

Working in the **Type of connection** window, you can choose between an FTP and an FTP/IP connection.

✓ *The Settings > Log settings > Network menu is open.*

1. Working in the **Network** menu, press the **FORWARD** or **BACK** key until the **Type of connection** window is displayed.

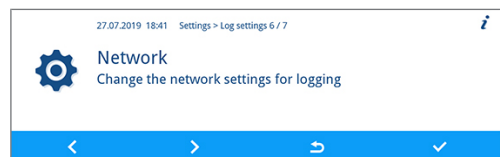

2. Press the **EDIT** key.



3. Press the **FORWARD** or **BACK** key to navigate between **0** (FTP) and **1** (TCP/IP).



4. Press the **CONFIRM** key to accept the change.



FTP password, TCP port

This example demonstrates how to set the FTP password. The TCP port is set in the same fashion.

✓ *The Settings > Log settings > Network menu is open.*

1. Working in the **Network** menu, press the **FORWARD** or **BACK** key until the **FTP password** parameter is displayed.



2. Press the **EDIT** key.

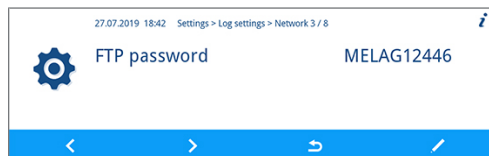

3. Press the **FORWARD** or **BACK** key to change the parameter.



PLEASE NOTE

Holding the **FORWARD** or **BACK** key pressed accelerates the increase or decrease.

4. Press the **CONFIRM** key to accept the change.



PLEASE NOTE

If the device is integrated in the (practice) network via a TCP connection, you will require a suitable program, e.g. MELAview/MELAt race.

Outputting graphic logs

Working in the **Graphic logs** submenu, you can select the output medium for automatic logging of graphic logs.

The following example describes how to select a CF card as an output medium for graphic logs. The selection of a different or a further output medium is performed in accordance with the same procedure.

Proceed as follows to select the output medium:

✓ *The Settings > Log settings menu is open.*

1. Working in the **Log settings** submenu, press the **FORWARD** or **BACK** key until the **Graphic logs** submenu is displayed.

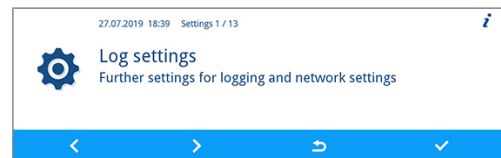

2. Press the **CONFIRM** key to open the submenu.



↳ You can make settings for the CF card and computer output medium.

3. Press the **EDIT** key to change the **CF card** parameter.

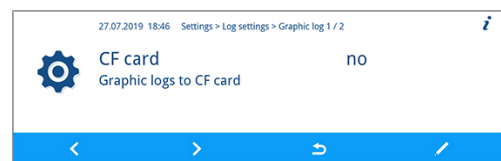

4. Press the **FORWARD** or **BACK** key to navigate between the **yes** and **no**.



5. Press the **CONFIRM** key to accept the change.

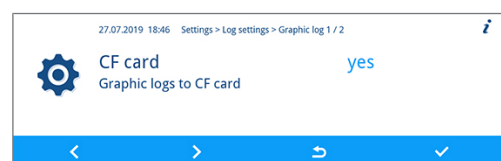

Setting the date and time

Correct batch documentation requires the correct date and time setting on the device.

Setting the date

The following example demonstrates the setting of the day parameter. Proceed in the same fashion to set the month and year parameters.

✓ *The Settings menu is open.*

1. Working in the **Settings** menu, press the **FORWARD** or **BACK** key until the **Date** submenu is displayed.

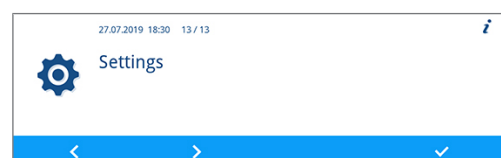

- Press the **CONFIRM** key to open the submenu.

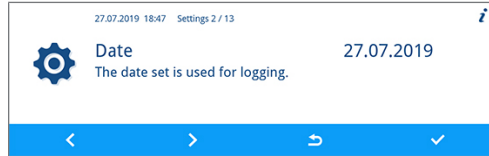

- Press the **EDIT** key.

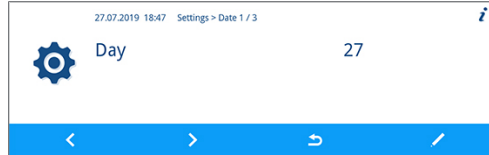

- Press the **FORWARD** or **BACK** key to change the parameter.

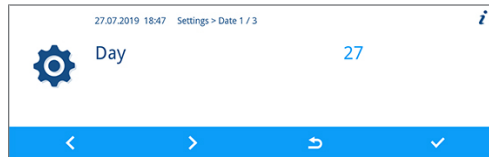

- Press the **CONFIRM** key to accept the change.

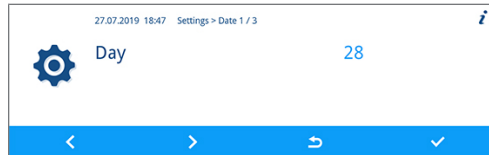

Setting the time

The following example demonstrates the setting of the hour parameter. Proceed in the same fashion to set the minute and second parameters.

✓ *The Settings menu is open.*

- Working in the **Settings** menu, press the **FORWARD** or **BACK** key until the **Time** submenu is displayed.

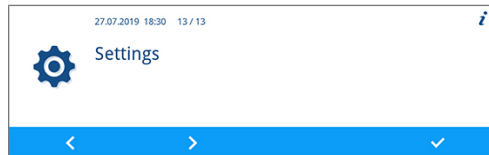

- Press the **CONFIRM** key to open the submenu.

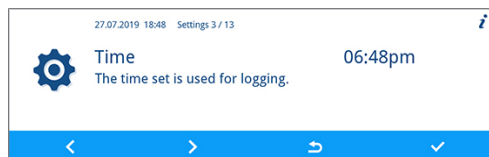

- Press the **EDIT** key.

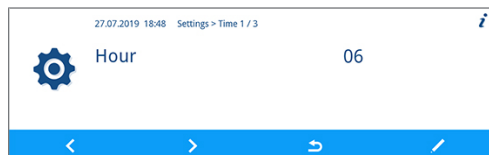

- Press the **FORWARD** or **BACK** key to change the parameter.

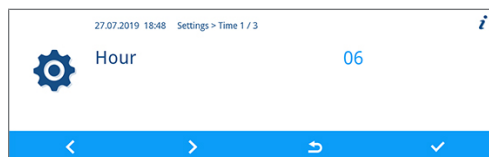

5. Press the **CONFIRM** key to accept the change.

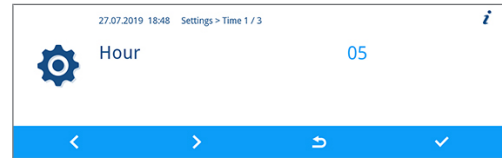

Setting the display brightness

Proceed as follows to set the display brightness:

- ✓ *The Settings menu is open.*

1. Working in the **Settings** menu, press the **FORWARD** or **BACK** key until the **Display brightness** parameter is displayed.

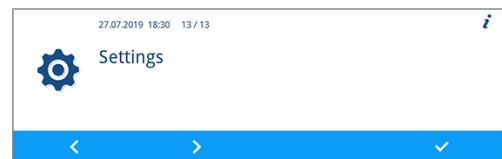

2. Press the **EDIT** key.

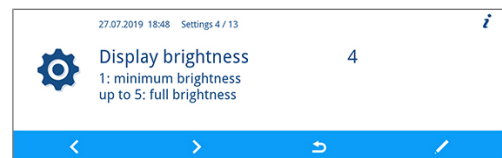

3. Press the **FORWARD** or **BACK** key to change the parameter. The colour bar gives an impression of the colour contrast.

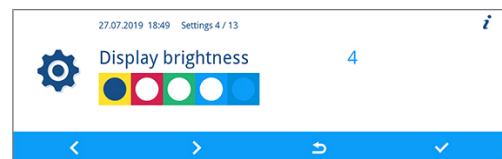

4. Press the **CONFIRM** key to accept the change.

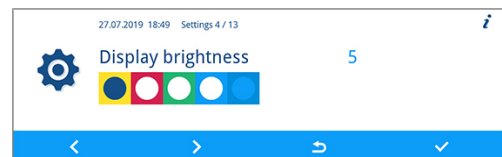

Setting the idle mode

Proceed as follows to set the idle mode:

- ✓ *The Settings menu is open.*

1. Working in the **Settings** menu, press the **FORWARD** or **BACK** key until the **Idle mode in min.**

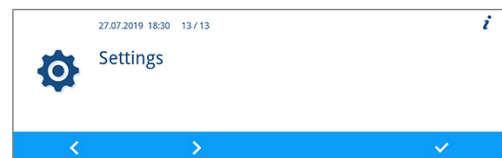

2. Press the **EDIT** key.



3. Press the **FORWARD** or **BACK** key to change the parameter.

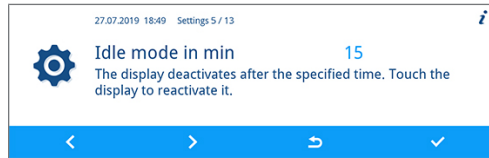

4. Press the **CONFIRM** key to accept the change.

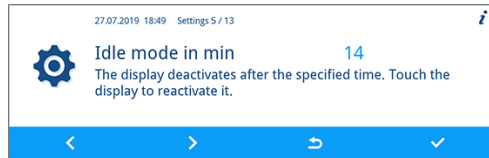

Setting the volume of the signal tone

Proceed as follows to set the volume of the signal tone:

✓ *The Settings menu is open.*

1. Working in the **Settings** menu, press the **FORWARD** or **BACK** key until the **Signal tone volume** is displayed.

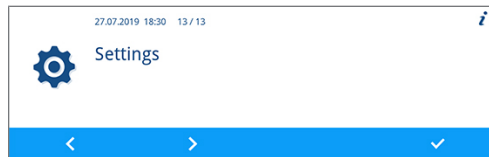

2. Press the **EDIT** key.



3. Press the **FORWARD** or **BACK** key to change the parameter.



4. Press the **CONFIRM** key to accept the change.



Setting the volume of the key tone

Proceed as follows to set the volume of the key tone:

✓ *The Settings menu is open.*

1. Working in the **Settings** menu, press the **FORWARD** or **BACK** key until the **Key tone volume** parameter is displayed.

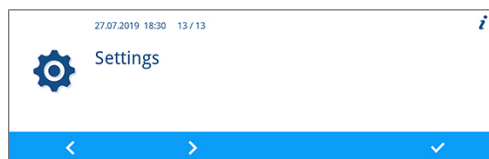

2. Press the **EDIT** key.

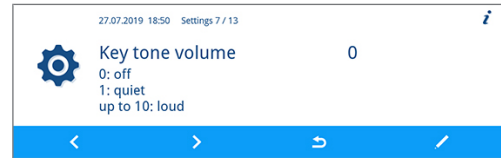

3. Press the **FORWARD** or **BACK** key to change the parameter.

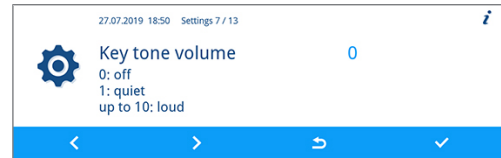

4. Press the **CONFIRM** key to accept the change.



Connectivity

Working in the **Connectivity** submenu, you can connect the device with the MELAconnect app. You can use this app to monitor instrument reprocessing performed on multiple devices in parallel and to access context-related troubleshooting assistance.

Proceed as follows to establish a connection between the device and the MELAconnect app:

- ✓ *The MELAconnect app is installed on your mobile end device (e.g. smartphone or tablet).*
- ✓ *The device is connected with the practice network, see [Setting the network](#) [▶ page 51].*
- ✓ *The **Settings** menu is open.*

1. Working in the **Settings** menu, press the **FORWARD** or **BACK** key until the **Connectivity** window is displayed.

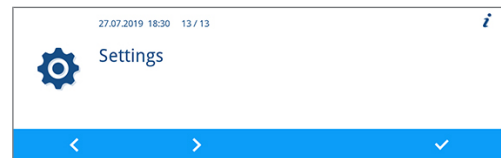

2. Press the **CONFIRM** key.

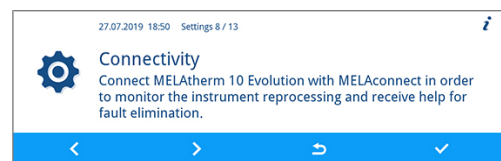

➔ The QR code is displayed in the place of the symbol in the main area of the display.

3. Open the MELAconnect app on your mobile end device.
4. Read in the QR code to your mobile end device using the MELAconnect app.

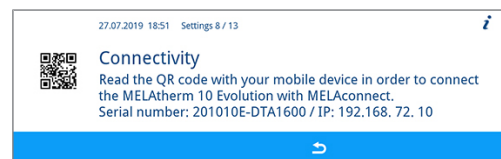

➔ The serial number and IP address of your device will be transferred to the app.

Alternatively, you can enter the IP address of your device in the MELAconnect app manually. With manual entry of the IP address: Owners of multiple MELAG devices of the identical type can differentiate between their devices by viewing serial number on the display to check whether MELAconnect has been connected to the correct device.

Setting the language

Proceed as follows to set the language:

✓ *The Settings menu is open.*

1. Working in the **Settings** menu, press the **FORWARD** or **BACK** key until the **Language** window is displayed.

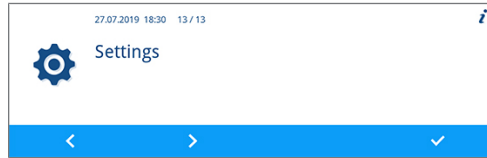

2. Press the **EDIT** key.

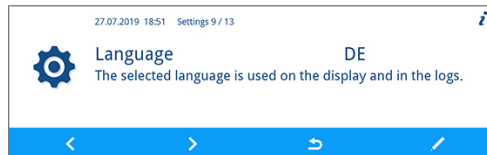

3. Press the **FORWARD** or **BACK** key to change the parameter.

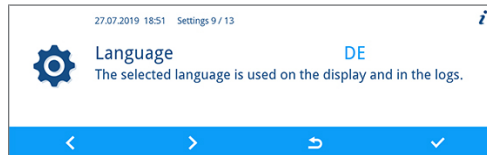

4. Press the **CONFIRM** key to accept the change.

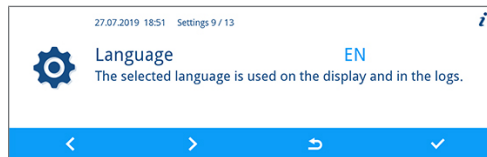

Setting the water supply

If the device is connected to a DI water supply e.g. MELAdem 53/MELAdem 53 C or another water treatment unit, this must be set on the device. In its delivery state, the water supply is set to **DI water yes**.



PLEASE NOTE

This setting is performed by the service technician during device commissioning.

Proceed as follows to set the DI water:

✓ *The Settings menu is open.*

1. Working in the **Settings** menu, press the **FORWARD** or **BACK** key until the **DI water** parameter is displayed.

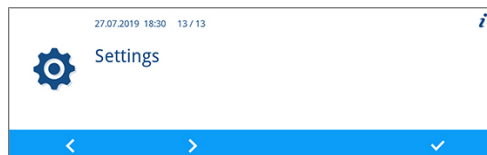

2. Press the **EDIT** key.

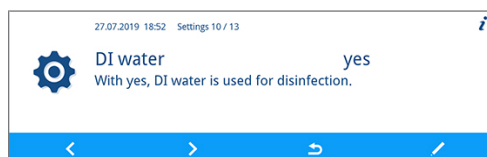

3. Press the **FORWARD** or **BACK** key to change the parameter.

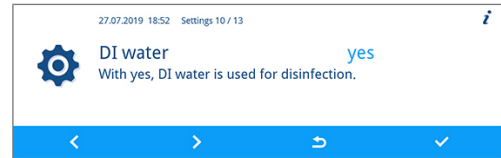

4. Press the **CONFIRM** key to accept the change.

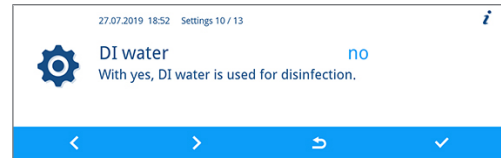

Setting the water hardness



PLEASE NOTE

The service technician determines and sets the water hardness during device commissioning.

Proceed as follows to set the water hardness:

- ✓ *The Settings menu is open.*

1. Working in the **Settings** menu, press the **FORWARD** or **BACK** key until the **Water hardness in °dH** is displayed.

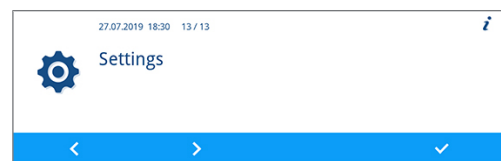

2. Press the **EDIT** key.

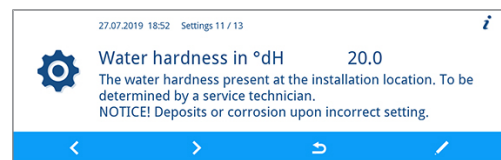

3. Press the **FORWARD** or **BACK** key to change the parameter.

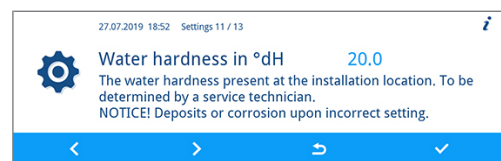

4. Press the **CONFIRM** key to accept the change.

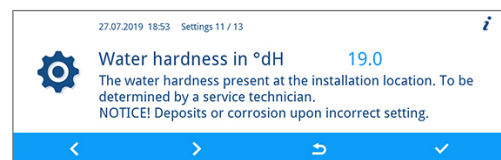

Administrative settings

Working in the **Administration** submenu, the administrator can assign user PINs to existing user IDs and can activate or deactivate the authentication and batch approval.

Logging on as an administrator

Proceed as follows to log on as an administrator:

✓ *The Settings menu is open.*

1. Working in the **Settings** menu, press the **FORWARD** or **BACK** key until **Administration** is displayed.

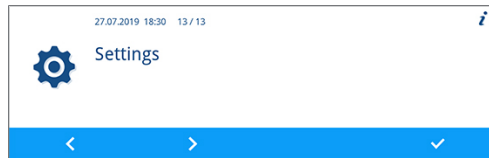

2. Press the **CONFIRM** key.

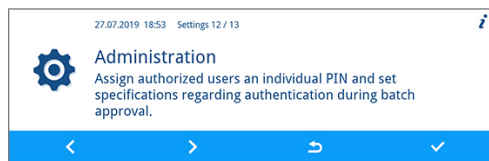

3. Enter the admin PIN (works-side admin PIN: 1000) and press the **CONFIRM** key.



➔ Successful login will result in display of the **User** window. You are logged in as an administrator.

Logging off as an administrator

Proceed as follows to log out as an administrator:

✓ *You are working in the Settings > Administration menu as an administrator.*

1. Working in any window, press the **LEAVE** key until the security query for leaving the settings has been displayed.

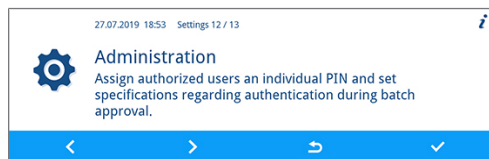

2. Press the **YES** key to leave the settings.

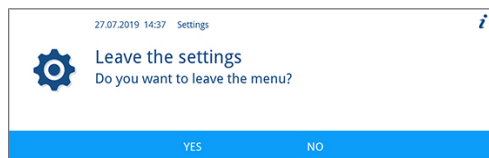

3. Press the **YES** or **NO** key to save or discard the settings.

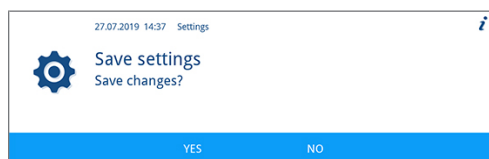

➔ The **Settings** menu is displayed. You have logged off as an administrator.

User

Twenty user IDs have been specified in the **Settings > Administration > User** menu. The administrator can assign a user PIN to every user ID and edit it. Every user PIN consists of four digits.

Creating and assigning a new user PIN

In its delivery state, the user IDs 2 to 20 have not been assigned a PIN. The administrator can create a user PIN for these IDs. User IDs without a user PIN are marked with a dash "-".



PLEASE NOTE

The PIN 1000 is reserved for the administrator and cannot be assigned to another user ID. This also applies when the admin PIN has been changed.

Proceed as follows to create a user PIN:

✓ You are working in the **Settings > Administration > User** menu and are logged on as an administrator, see [Administrative settings](#) [▶ page 61].

1. Working in the **User** submenu, press the **FORWARD** or **BACK** key until the user ID (from 2 to 20) is displayed without the PIN.

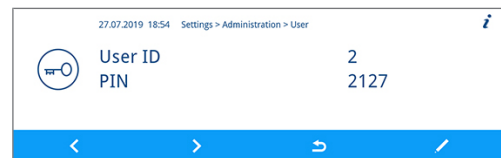

2. Press the **EDIT** key.

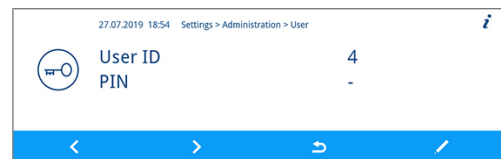

3. Select four digits from 0 to 9 to create a user PIN.

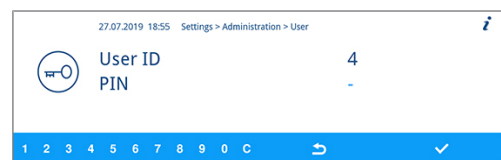

4. Press the **CONFIRM** key to assign the displayed user ID.

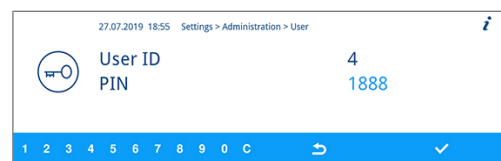

User PIN already issued

Should you wish to confirm a user PIN which has already been issued, the following notification will be displayed: **PIN already assigned!** This PIN will not be assigned to the user ID displayed and must be changed.

1. Working in the action bar, press **C** repeatedly until all the digits to be changed have been deleted.

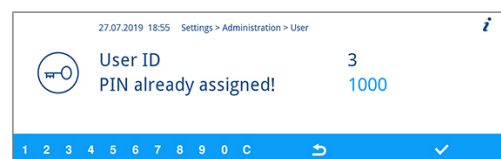

2. Working in the action bar, select digits from 0 to 9 to change the four-digit PIN.

- Press the **CONFIRM** key to assign the altered PIN to the displayed user ID.

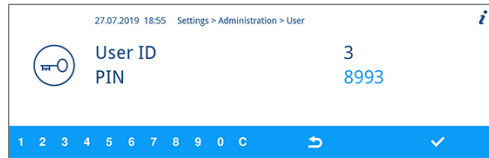

➡ If the user PIN has not been assigned, the colour of the altered PIN changes from light to dark blue.

Changing an existing admin/user PIN

In its delivery state, the admin PIN is set to 1000 as standard. MELAG recommends that you change the admin PIN upon commissioning. The admin PIN (user ID 1) can be changed just as a user ID (user ID 2-20).



PLEASE NOTE

Should you loose the altered admin PIN, contact an authorized customer services or a stockist technician.

Proceed as follows to change an existing PIN:

- ✓ You are working in the *Settings > Administration > User* menu and are logged on as an administrator, see [Administrative settings](#) [▶ page 61].

- Working in the **User** submenu, press the **FORWARD** or **BACK** key until the user ID with the PIN to be changed is displayed.

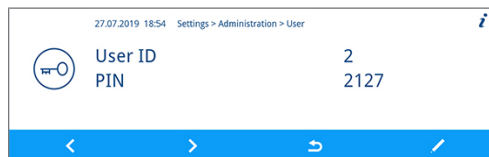

- Press the **EDIT** key.

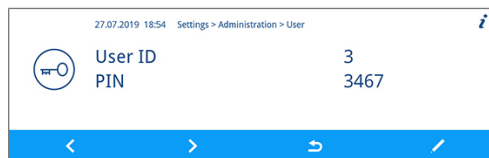

- Working in the action bar, press **C** until all the digits to be changed have been deleted.

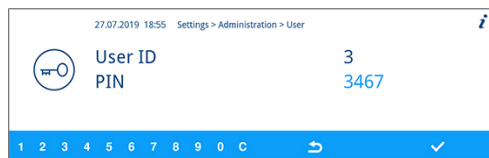

- Working in the action bar, select digits from 0 to 9 to generate the four-digit PIN.

- Press the **CONFIRM** key to assign the altered PIN to the displayed user ID.

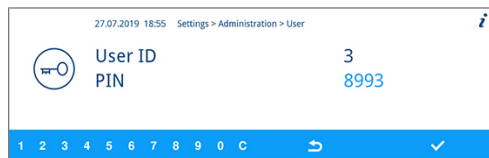

Deleting the user PIN

Proceed as follows to delete a user PIN:

- ✓ You are working in the *Settings > Administration > User* menu and are logged on as an administrator, see [Administrative settings](#) [▶ page 61].

1. Working in the **User** submenu, press the **FORWARD** or **BACK** key until the user ID (from 2 to 20) is displayed with the PIN to be deleted.

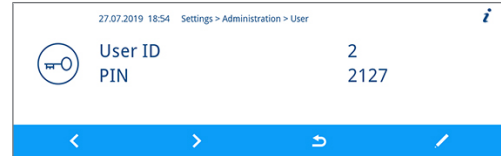

2. Press the **EDIT** key.

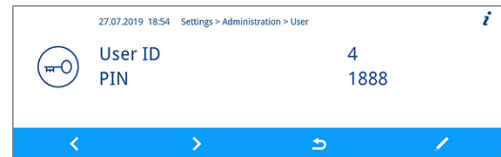

3. Working in the action bar, press **C** repeatedly until all four digits have been deleted and a dash "-" is displayed.

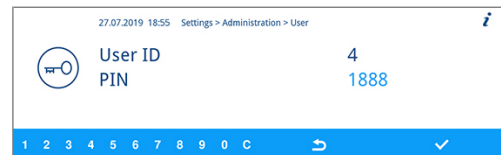

4. Press the **CONFIRM** key to accept the change.



➔ The user ID no longer has a user PIN assigned to it.

Authentication

The administrator can activate or deactivate user authentication. In its delivery state, authentication is deactivated as standard (= inactive).

Activating authentication

Proceed as follows to activate authentication:

- ✓ You are working in the *Settings > Administration* menu and are logged on as an administrator, see [Administrative settings](#) [▶ page 61].

1. Working in the **Administration** submenu, press the **FORWARD** or **BACK** key until the **Authentication** window is displayed.

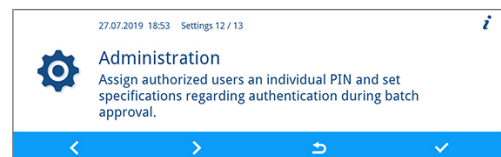

2. Press the **EDIT** key.

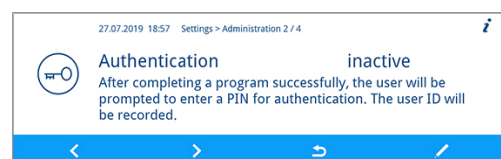

3. Press the **FORWARD** key.

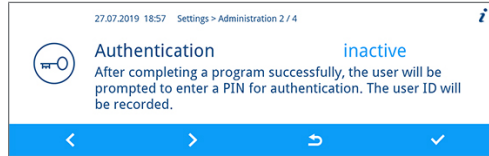

↳ The setting changes from **inactive** to **active**.

4. Press the **CONFIRM** key to accept the change.

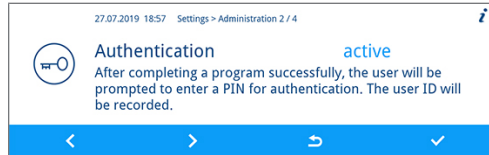

↳ Authentication has been activated. The log states **User ID: ##**.

Deactivating authentication

▶ Authentication is deactivated in the same way as it is activated.

↳ The setting changes from **active** to **inactive**.

↳ The log states **User ID: Deactivated**.

Batch approval

The administrator can activate or deactivate batch approval. In its delivery state, batch approval is deactivated as standard (= inactive).

Activating batch approval

Proceed as follows to activate batch approval:

✓ *You are working in the **Settings > Administration** menu and are logged on as an administrator, see [Administrative settings](#) [▶ page 61].*

1. Working in the **Administration** submenu, press the **FORWARD** or **BACK** key until the **Batch approval** parameter is displayed.

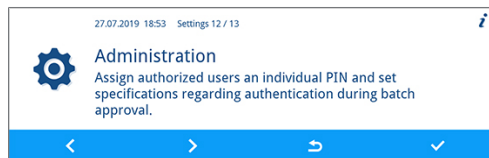

2. Press the **EDIT** key.

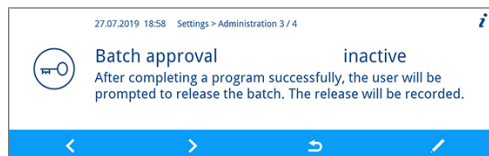

3. Press the **FORWARD** key.

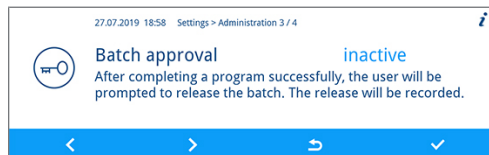

↳ The setting changes from **inactive** to **active**.

4. Press the **CONFIRM** key to accept the change.

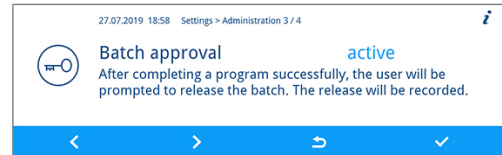

- Batch approval has been activated. The log states **Approve batch: YES** or **NO**.

Deactivating batch approval

- ▶ Batch approval is deactivated in the same way as it is activated.
- The setting changes from **active** to **inactive**.
- The log states **Approve batch: Deactivated**.

9 Function tests

Automatic and manual functional check

Automatic

The device components are monitored and checked automatically for their functionality and interplay. Should the parameter thresholds be exceeded, the device will issue warnings or malfunction messages. If necessary, it will abort a program with the relevant notification. The device will also display messages when a program has been completed successfully.

Manual

You can follow the program run on the display and use the log recorded to check the success of a program. Further information is provided in chapter [Logging](#) [▶ page 41].

Measuring conductivity

You can access the water quality of the DI water on the display at any time.

1. Press the **FORWARD** or **BACK** key repeatedly until the additional program "Conductivity measurement DI" is displayed.
2. Press the **START** key to start the additional program.

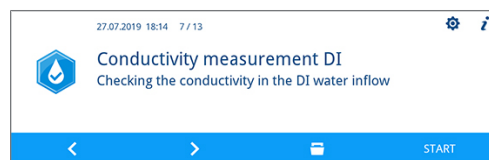

10 Maintenance



WARNING

All servicing work, especially that performed in the washing chamber may only be performed after a successful disinfection program.

- Comply with the working safety regulations.

Regular checks and cleaning



NOTICE

Incorrect cleaning can damage the surfaces and sealing faces. Scratched or damaged surfaces and leaking sealing faces favour soiling deposits and corrosion in the washing chamber.

- Comply with all information regarding cleaning of the parts affected.



NOTICE

When the coarse and fine sieves are missing, residue may enter the flushing circuit and impair the device function.

- Ensure that the coarse and fine sieves are always in place before program start.

Check the sieves in the washing chamber

A coarse and a fine sieve are fitted in the washing chamber. The sieves are designed to hold back dirt particles or soiling from the instruments. They can become blocked over time.

1. Inspect the coarse and the fine sieves for soiling and small components which have fallen from the load.
2. Turn the grip of the coarse sieve leftwards to its fullest extent and remove it upwards.

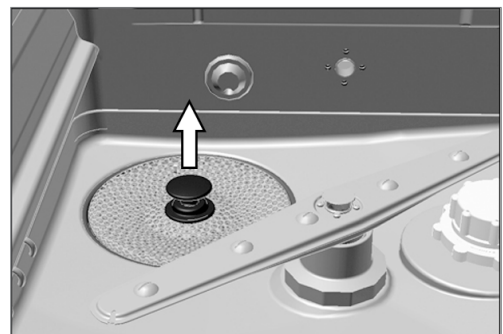

3. Turn the knurled nut on the fine sieve leftwards and remove the fine sieve upwards.
4. Inspect the coarse and the fine sieves for soiling.
5. Rinse the soiled sieve under running water. Do not use any dish-washing detergent. Remove any deposits with a soft brush.

Check the rinse arms

Soiling can block the nozzles of the rinse arms. Check both rinse arms regularly and rinse the nozzles if necessary.

1. Check that the coarse and the fine sieves are installed.
2. Turn the knurled nut on the rinse arm leftwards and remove the rinse arm.

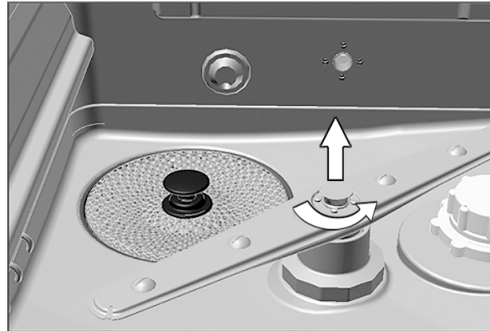

3. Clean blocked nozzles with a thin pointed object.

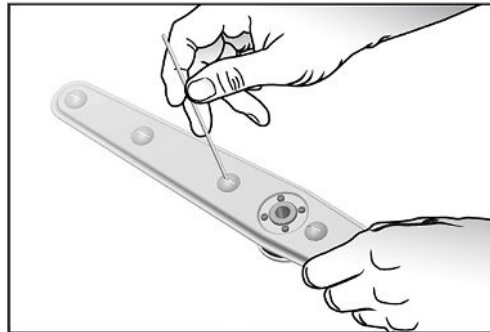

4. Return the rinse arms and ensure their smooth running as well as free movement.

Check the door seal

Check the door seal for impurities, deposits or damage on a daily basis. If necessary, clean the door seal with a moist, non-fuzzing cloth and conventionally-available neutral liquid cleaning fluid.

Check the injector rail nozzles for free passage

We recommend checking the injector rail nozzles for their free passage on a monthly basis.

To test whether the injector rail nozzles are blocked, they must be held upright under running water. If the water flows freely through the nozzles, they are not blocked.

Check the accessories

Check the accessories in particular with regard to the plastic parts (e.g. inserts) for damage, deposits and soiling on a monthly basis, unless the document *Instructions for the use and care of the accessories* indicates otherwise.

Cleaning on demand

Operating unit and plastic front

Comply with the following specifications for cleaning:

- ▶ Use a soft, non-fuzzing cloth.
- ▶ Use a chlorine- and vinegar-free cleaning fluid or a plastics cleaning agent.
- ▶ Check the material compatibility before application.
- ▶ Never use solvents or benzene.
- ▶ Use surface disinfectants which are suitable for plastics. Observe the manufacturer's information on the respective surface disinfectant.

Pump pit and non-return valve

If the rinse water has not been removed entirely after a program, the non-return valve must be cleaned.

1. Remove the coarse and fine sieves and remove the residue and deposits from the pump pit.
2. Remove the non-return valve upwards by pulling on its grip and pull it out of the pump pit.

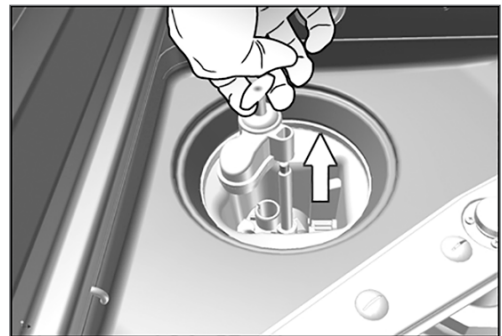

3. Clean the non-return valve under running water. Do not use any dishwashing detergent.
4. Replace the non-return valve and the fine and coarse sieve in the pump pit.
5. Start the "Rinsing" program.

Avoiding staining

Stains on the instruments or the device can develop from poor water quality. In particular, heavy metals or chloride deposits can result in the development of stains and rust. To avoid the development of stains on the instruments or the washing chamber, we recommend a final rinse with deionised water (DI water). All water-conducting parts of the device are made of non-rusting materials. This excludes the formation of stains or rust caused by the device. Often a rust-producing instrument already suffices for third-party rust to form on the other instruments or in the device. Further information is provided in the latest Red brochure *Instrument Reprocessing - Reprocessing of Instruments to Retain Value* by the AKI²⁾, see the chapter "Surface Changes: Deposits, Discoloration, Corrosion, Aging, Swelling and Stress Cracks".

²⁾Arbeitskreis Instrumenten-Aufbereitung (Instrument Reprocessing Working Group)

Changing the filter in the drying fan

Exceeding the permissible level of blockage can result in a worsened drying outcome. For this reason, the device checks the degree of blockage automatically. Exceeding the tolerances results in the issue of the relevant display message.



WARNING

Careless touching of the HEPA filter may damage the lamellae.

This may impair filter services and recontamination of the disinfected instruments.

- Only touch the HEPA filter by the frame and do not damage the lamellae.



PLEASE NOTE

The pre-filter and the HEPA filter are replaced within the scope of the maintenance on hygienic grounds.

1. Pull the process agent drawer forwards.

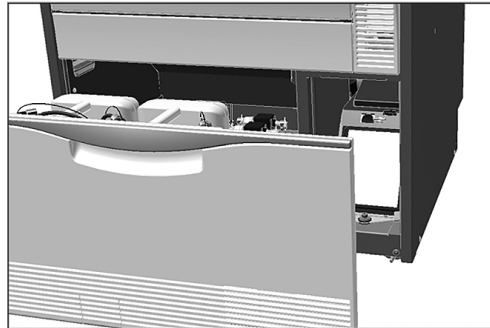

2. Undo the screw on the cover cap of the drying fan by hand and lift up the cover cap.

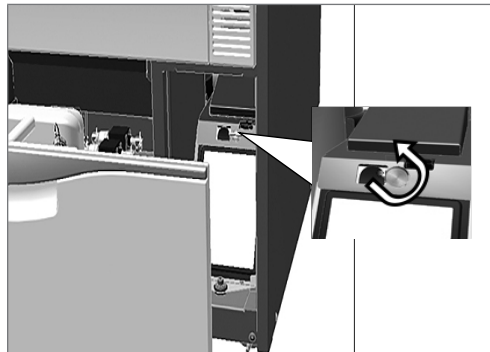

3. Pull out the pre-filter upwards and change it.

4. Pull out the HEPA filter upwards and change it.



5. Close the cover cap and turn the screw hand-tight.

Maintenance



NOTICE

Continuing operation beyond the maintenance interval can result in malfunctions in the device.

- Maintenance should only be performed by trained and authorized service technicians or stockist technicians.
- Maintain the specified servicing intervals.

Regular maintenance is vital to ensure reliable operation and value retention of the device. All function and safety-relevant components and electrical units are checked during maintenance and replaced where necessary. The maintenance is performed by an authorized customer services/stockist technician working in accordance with the maintenance instructions. A freely-accessible device has a maintenance time of approx. three hours plus a test run plus any work not foreseen by the maintenance plan.

The maintenance is to be performed regularly after 1000 cycles or at the latest 24 months.

(Process) Validation

A reproducible cleaning and disinfection outcome can only be ensured via correct operation (inc. use of suitable accessories). The practice operator is responsible for ensuring reproducibility through the use of batch controls, routine checks and/or periodic inspections (e.g. validation).

This requirement is made (in Germany) by e.g. the *Medizinprodukte-Betreiberverordnung* (§ 8 Abs. 2 MPBetreibV), DGKH, DGSV and AKI directives and the recommendations from the Robert-Koch-Institut. This requirement is also made in international regulations. This is based on DIN EN ISO 15883, which is also valid in Germany.

Comply with all valid national regulations and specifications. In case of doubt, consult the relevant professional association.

- Only use the loading pattern specified and approved within the scope of the validation.
- The usage of process agents that are not recommended by MELAG (see [Process agents](#) [▶ page 10]) may cause an increased effort for validation / performance requalification.
- We cannot provide a guarantee for non-MELAG accessories, even if they are in possession of validation.
- The validator and technical service can download a "Recommendation for validating the MELAtherm 10 Evolution" (doc.: AS_007-19) from the MELAG service portal.

11 Pause times

Pause times between individual programs are not necessary. Instruments can be re-arranged and then cleaned and disinfected after a program run or abort.

Run the "Rinsing" program twice before reprocessing following pause times longer than two days e.g. following a weekend.

After pause times longer than two days in the ophthalmic sector, run an empty batch in Ophthalmic-Program to flush the DI cartridge.

Long operating pauses (longer than two weeks)

- Decommission the device if you plan to have a pause of over two weeks.

Decommissioning

Preparation for transport

Decommissioning in preparation for transport outside the practice should only be undertaken by MELAG-authorized individuals.

Following longer operating pauses



WARNING

Danger of acid burns by irritant substances!

Improper handling of the process agents may cause caustic burns and health damage.

- Protect your eyes, hands, clothing and all surfaces from contact with the process agents.
- Comply with the information from the manufacturer of the process agents.
- Every type of fluid (e.g. in the drawer, in the device floor tank or fluid emerging from the device) issued from the device as the result of damage could potentially contain aggressive process agents.

When decommissioning the device for a long pause (e.g. due to holiday), proceed as follows:

1. Remove the suction lances from the containers and place them in a container with water. The suction lances should be immersed to a minimum of 80 %.
2. Run the "Air removal" program to free the metering system from process agents.
3. Return the suction lances to the process agents and screw them on tightly.
4. The interior of the washing chamber must be dry.
5. Switch off the device at the power switch.
6. Disconnect the power plug from the socket.
7. Turn off the water inflow.

Recommissioning



NOTICE

Before running the first reprocessing program, the "Air removal" program must be performed twice. Then start the usual disinfection program with an unloaded basis basket.

- ▶ Comply with the specifications pertaining to recommissioning outlined in the chapter [First steps](#) [▶ page 20].

Transport within the practice



CAUTION

Danger of injury from incorrect carrying.

Lifting and carrying too heavy a load can result in spinal injury. Failure to comply with these provisions can result in crushing.

- Comply with the safety regulations issued by your professional association.
-

Comply with the following provisions pertaining to transport within the practice:

- ▶ Empty the device entirely.
- ▶ Remove the inserts and the basis basket.
- ▶ Seal the water inflow hose.
- ▶ Close the door before moving the device.
- ▶ Avoid strong vibrations.

Frost protection

Operate the device in a generally frost-free environment. Should any residual fluids freeze in the device, the device should be held at room temperature for a minimum of two hours so that they can thaw.

Recommissioning after relocation

When recommissioning after a move, proceed as with the first commissioning (see chapter [First steps](#) [▶ page 20]).

12 Malfunctions

Not all notifications on the display are malfunction messages. Messages are issued on the display with an event number. The number serves identification purposes for obtaining assistance on the MELAG website (Service > Troubleshooting), the MELAconnect app and when communicating with the authorized customer services or the stockist technician.

General events

General events serve to provide information and assistance in the operation of the device. Malfunction-free operation of the device is still possible.

▶ Example:

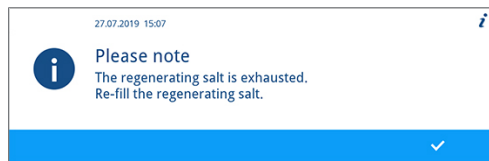

Warning

A warning helps to ensure malfunction-free operation and recognition of undesirable situations. React to a warning quickly to prevent the resulting malfunction.

▶ Example:

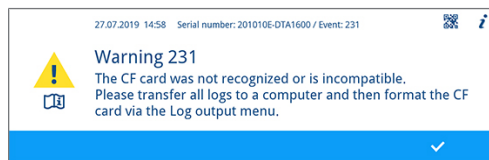

Malfunction message

Malfunction messages are issued when it is not possible to ensure safe operation or cleaning and disinfection. These can appear on the display shortly after switching on or during a program run. If a malfunction occurs during a program run, the program will be aborted and will be classed as unsuccessful.

▶ Example:

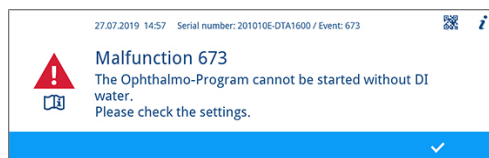

WARNING

Danger of infection from program abort.

If a program is interrupted before the start of a drying phase, the load is taken as not having been cleaned and disinfected. This endangers the health of the patient and the practice team.

- Only abort a current program in exceptional reasons.
- Never open the door after a program start.
- Reprocess the instruments again after a program abort.

Displaying events in MELAconnect

You can use the MELAconnect app to access the information required to rectify a malfunction. A QR code is displayed in the context menu following warnings and malfunction messages.

Proceed as follows to transfer event data:

✓ *The device is connected to the MELAconnect app, see [Connectivity](#) [▶ page 58].*

1. Working in the context menu, press the **QR CODE** key.
2. Open the MELAconnect app on your mobile end device and select the **Troubleshooting** menu.
3. Scan the QR code on the MELAtherm display (left next to the event text).

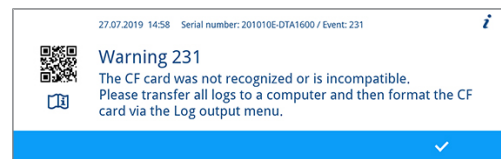
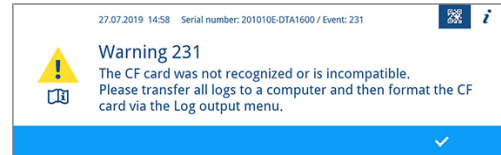

➔ The serial number of the device and the event number are transferred to the MELAconnect app and context-related information pertaining to the cause of the problem and its remedy is displayed.

Alternatively, you can enter and search for the event number directly in MELAconnect app.

With devices already subject to monitoring, the MELAconnect app sets a link with further information directly in the warning or malfunction message displayed.

General events



CAUTION

Danger of injury from insufficient protective measures!

Performing work without first taking the corresponding protective measures can result in injuries.

- Comply with the working safety measures required by the respective tasks.

The following tables indicate possible causes for certain events and the corresponding operating information for their remedy. Should you be unable to find the relevant event, or your efforts do not redress the problem, you can contact your nearest stockist or authorized MELAG customer service provider. Please have your device serial number, the event number and/or a detailed description of the message contained in the notification to hand.

Event	Possible cause	Remedy
Banging or rattling noise in the washing chamber during a program run.	The rinse arm bangs against instruments or containers. The load moves in the washing chamber.	Interrupt the program and re-arrange the load. Start the program again.

Event	Possible cause	Remedy
White layer on the instruments	The internal water softening unit has not been programmed correctly.	Check the water hardness of the tap water and reset the internal water softening unit if necessary, see Description of the device [▶ page 11].
	Water-insoluble, hardened treatment residue (e.g. dental cement or root canal disinfectants) remain on the instruments.	Remove the treatment residue manually immediately after instrument application.
	Ultrasound gel residue can be found on the instruments.	Avoid the use of Quats-based (quaternary ammonium cation) cleaning fluids and disinfectants in the manual pre-cleaning of instruments with gels or lubricants. Gels with thickening agents, especially polyacrylic acid separate after contact with Quats. Should you prefer to change gels, products with cation-compatible thickening systems are suitable. Consult the gel manufacturer or the process agents manufacturer for further information.
Poor cleaning outcome	The basis basket / insert baskets / insert racks are incorrectly loaded or are too full.	Ensure correct arrangement and avoid overloading.
	Load produces spray shadow.	Ensure the correct arrangement of the instruments.
	The cleaning agent is unsuitable for this type of soiling.	Use a suitable cleaning agent for automatic cleaning.
	Encrusted soiling on the instruments.	Do not allow soiling to dry on. Rinse off soiling immediately.
	Rinse arm nozzles or injector rail nozzles blocked.	Rectify the blockage in accordance with the description provided in the chapter Maintenance [▶ page 68].
	Pump pit sieves are soiled.	Clean the coarse and fine sieves in accordance with with the description provided in the chapter Maintenance [▶ page 68].
Empty display	The device is not switched on.	Check that the device is connected to the power supply and is switched on.
	The fuse in domestic installation has tripped. This can be caused by operating a number of electrical devices at the same time.	Check the house fuse (see type plate for the minimum fuse).
Residual moisture on and/or on the instruments.	The basis basket / insert baskets / insert racks are incorrectly loaded or are too full.	Ensure correct arrangement and avoid overloading.
	The interior structure of the instruments is too complex or the interior volume is insufficient.	Dry the instruments with clean (medical) compressed air.
Display: The regenerating salt is exhausted. Re-fill the regenerating salt.	The regenerating salt is exhausted.	Fill the salt container with regenerating salt. The signal (a tone) informs the operator that the salt in the salt container has been recognized and that operation can be continued.

Warnings

Event	Possible cause	Remedy
214	The CF card was removed from the slot during a running program and re-inserted.	Once the program has been completed, working in the display, select the Log output and output the current log. Do not remove the CF card during active logging. Logging is active when the red LED illuminates.
215 216 217	The CF card does not function correctly. The system does not recognize a CF card or is unable to read it.	1. Save the log on an external data carrier. 2. Working in the display, select the Log output menu and navigate to CF card formatting . Format the CF card in the device.
	The CF card memory is too large (max. 4 GB).	Insert a CF card with a memory of up to 4 GB. The MELAG logo must point rightwards during insertion. MELAG recommends using original accessories only.
218	Whilst outputting the logs via the Log output menu, a log was recognized on the CF card.	Acknowledge the message with the CONFIRM key. The existing log will not be overwritten.
219 220	The CF card does not function correctly. The system does not recognize a CF card or is unable to read it.	1. Save the log on an external data carrier. 2. Working in the display, select the Log output menu and navigate to CF card formatting . Format the CF card in the device.
	The CF card memory is too large (max. 4 GB).	Insert a CF card with a memory of up to 4 GB. The MELAG logo must point rightwards during insertion. MELAG recommends using original accessories only.
221	The CF card memory is full. No further logs can be saved.	1. Save the log on an external data carrier. 2. Working in the display, select the Log output menu and navigate to CF card formatting . Format the CF card in the device.
222 223 224 225	The CF card does not function correctly. The system does not recognize a CF card or is unable to read it.	1. Save the log on an external data carrier. 2. Working in the display, select the Log output menu and navigate to CF card formatting . Format the CF card in the device.
226 227	The CF card memory is too large (max. 4 GB).	Insert a CF card with a memory of up to 4 GB. The MELAG logo must point rightwards during insertion. MELAG recommends using original accessories only.
228	The CF card is too slow. Either the CF card is no longer recognized following a reset or it was inserted in the slot under voltage.	1. Save the log on an external data carrier. 2. Insert a new CF card (max. 4 GB) in the card slot. The MELAG logo must point rightwards during insertion. MELAG recommends using original accessories only.

Event	Possible cause	Remedy
229	The CF card was removed from the slot during a writing action.	If the program has been concluded, working in the display, select the Log output menu and output the current log. Do not remove the CF card during active logging. Logging is active when the red LED illuminates.
230	The CF card does not function correctly. The system does not recognize a CF card or is unable to read it.	<ol style="list-style-type: none"> 1. Save the log on an external data carrier. 2. Working in the display, select the Log output menu and navigate to CF card formatting. Format the CF card in the device.
	The CF card memory is too large (max. 4 GB).	<p>Insert a CF card with a memory of up to 4 GB. The MELAG logo must point rightwards during insertion.</p> <p>MELAG recommends using original accessories only.</p>
231	The CF card does not function correctly. There is no CF card in the slot.	<p>Insert a CF card with a memory of up to 4 GB. The MELAG logo must point rightwards during insertion.</p> <p>MELAG recommends using original accessories only.</p>
	The system does not recognize a CF card or the CF card cannot be read.	Push the CF card in the card slot until it the ejector key triggers.
232	The CF card does not function correctly.	Acknowledge the message with the CONFIRM key.
233	The CF card is currently being initialized or written.	
234 235 236 237	The CF card does not function correctly. The system does not recognize a CF card or is unable to read it.	<ol style="list-style-type: none"> 1. Save the log on an external data carrier. 2. Working in the display, select the Log output menu and navigate to CF card formatting. Format the CF card in the device.
	The CF card memory is too large (max. 4 GB).	<p>Insert a CF card with a memory of up to 4 GB. The MELAG logo must point rightwards during insertion.</p> <p>MELAG recommends using original accessories only.</p>
238	The CF card is not functioning correctly and cannot be formatted.	<p>Insert a new CF card (max. 4 GB) in the card slot. The MELAG logo must point rightwards during insertion.</p> <p>MELAG recommends using original accessories only.</p>
239 240	The CF card does not function correctly. The system does not recognize a CF card or is unable to read it.	<ol style="list-style-type: none"> 1. Save the log on an external data carrier. 2. Working in the display, select the Log output menu and navigate to CF card formatting. Format the CF card in the device.
	The CF card memory is too large (max. 4 GB).	<p>Insert a CF card with a memory of up to 4 GB. The MELAG logo must point rightwards during insertion.</p> <p>MELAG recommends using original accessories only.</p>

Event	Possible cause	Remedy
372	The internal log memory of the device is full. Not all logs have been outputted.	<ol style="list-style-type: none"> Working in the display, select the Log output menu and output the logs of the internal memory. Start the program again. If this notification is displayed repeatedly, delete the internal memory.
377	The system does not recognize an output medium. The system does not recognize a log printer, even though it is connected.	Check the settings in the Settings > Log settings menu.
	Working in the Settings > Log settings menu, at least one output is active and Immediate output has been set to yes . However, a log printer is not connected.	<ol style="list-style-type: none"> Working in the display, select the Log output menu and save the log on the CF card or the computer. Open the Settings > Log settings menu and deactivate Immediate output. The display changes from yes to no.
386	The device internal log memory contains logs which have yet to be outputted. The memory is almost full.	Acknowledge the message with the CONFIRM key. The program starts. As soon as the program has ended, working in the display, select the Log output menu and output all the logs in the internal memory (CF card or external data carrier).
394	Not all logs from the internal device memory have been saved on the CF card.	Acknowledge the message with the CONFIRM key. The logs are written and saved on the CF card.
395	Not all logs have been outputted from the internal device log memory via the EDM printer.	Acknowledge the message with the CONFIRM key. The logs will be outputted and printed.
396	Not all logs have been loaded onto the FTP server from the internal log memory of the device.	Acknowledge the message with the CONFIRM key. The logs are outputted and saved.
397	The system is unable to locate a computer for log output. <ol style="list-style-type: none"> Even though the device is connected to a computer, it is unable to establish a connection for log output. The device is not connected to a computer, but in the Settings menu, the Computer parameter is set to yes (active). 	<ol style="list-style-type: none"> Check the network connection to the computer / server. Switch on the computer / server. Restart the documentation software.
	The MELAG device is not connected to a computer, but in the Settings > Log settings menu, the Computer parameter is set to yes (active).	Working in the display, select the Settings > Log settings menu and deactivate the Computer parameter. The display changes from yes to no .
414	The rinse aid has been exhausted.	<ol style="list-style-type: none"> Replace the rinse aid container, working in accordance with the working safety regulations. Alternatively, refill. Start the "Air removal" program. <p>NOTICE! Use only process agents which you have used before.</p>

Event	Possible cause	Remedy
424	The neutralizer has been exhausted.	<ol style="list-style-type: none"> 1. Replace the neutralizer container, working in accordance with the working safety regulations. Alternatively, refill. 2. Start the "Air removal" program. <p>NOTICE! Use only process agents which you have used before.</p>
425	The cleaning agent has been exhausted.	<ol style="list-style-type: none"> 1. Replace the cleaning agent container, working in accordance with the working safety regulations. Alternatively, refill. 2. Start the "Air removal" program. <p>NOTICE! Use only process agents which you have used before.</p>
428	There is almost no regeneration salt left.	Fill regenerating salt, see Filling the regenerating salt [▶ page 24].
447	The rinse pressure in the washing chamber is too low. Large containers with the opening pointing upwards may have been sorted into the device. This diverts water from the rinsing process.	Setup the containers with their openings facing downwards.
450	The water inflow is insufficient.	Check the water supply of the device. Open the water inflow tap completely.
475	The HEPA filter in the drying fan is soiled.	Replace the HEPA-filter in the drying fan, see Changing the filter in the drying fan [▶ page 71].
477	The requisite pressure for the drying has not been achieved.	Replace the drying fan pre-filter, see Changing the filter in the drying fan [▶ page 71].
	The pre-filter in the drying fan is soiled.	
	The lid of the drying fan has not been locked correctly.	Lock the lid of the drying fan correctly.
478	The HEPA filter and the pre-filter in the drying fan are soiled.	Replace the HEPA-filter and the pre-filter, see Changing the filter in the drying fan [▶ page 71].
500	The display of the date and time of the system clock are incorrect.	Working in the display, select the Settings menu and set the date and time correctly, see Setting the date and time [▶ page 54].
501	The CF card does not function correctly. There is no CF card in the slot.	Insert a CF card with a memory of up to 4 GB. The MELAG logo must point rightwards during insertion. MELAG recommends using original accessories only.
	The system does not recognize a CF card or the CF card cannot be read.	Push the CF card in the card slot until the ejector button triggers.
502	The system is unable to locate a computer for log output. The network connection has been interrupted.	Check the network connection to the computer / server.
	The computer / server is not switched on.	Switch on the computer / server.
	The documentation software has not been started.	Restart the documentation software.
	A computer has not been connected, but in the Settings > Log settings menu, the Computer parameter is set to yes (active).	Working in the display, select the Settings > Log settings menu and deactivate the Computer parameter. The display changes from yes to no .

Event	Possible cause	Remedy
533	The temperature in the washing chamber is very high. The door is blocked and cannot be unlocked immediately.	CAUTION! The instruments are hot. Press the YES key, to acknowledge the message. The door can be opened. PLEASE NOTE: Take suitable safety precautions when opening the device, such as standing at a safe distance and wearing heat-proof gloves when opening the device.
534	The temperature in the washing chamber is very high. The door is blocked and cannot be unlocked immediately.	CAUTION! Danger of scalding! The instruments are hot. 1. Wait until the temperature of the washing chamber has cooled. 2. Working in the display, press the CONFIRM key.
560	The maximum permissible mains voltage (270 V) has been exceeded.	Have the connection conditions checked by an electrician.
561	The minimum permissible mains voltage (190 V) was undercut.	Have the connection conditions checked by an electrician.
562	The maximum permissible mains frequency (63 Hz) was exceeded.	Have the connection conditions checked by an electrician.
563	The minimum permissible mains frequency (45 Hz) was undercut.	Have the connection conditions checked by an electrician.
575	The date and time are invalid.	Check the settings in the Settings menu.
622	The maximum permissible maintenance period (24 months) or the maximum permissible number of cycles (1000 cycles) has been reached since commissioning or the last maintenance.	Arrange for maintenance with an authorized customer services or a stockist technician. You can continue to start the device.
625	The temperature during pre-cleaning is too high. The temperature during the water inflow is higher than 45 °C.	Check the water supply to the device.
671	Insufficient conductivity (> 15 µS/cm and < 25 µS/cm) was measured in the washing chamber during disinfection during disinfection in the Ophthalmo-Program. This could be caused by carry-over of process agents, regenerating salt or deposits. The program successfully completed despite the warning.	1. Close the lid of the salt container correctly. 2. Setup the containers in the device with their openings facing downwards. 3. Check the hollow bodies before reprocessing for their free passage and correct position. 4. Clean the filter screen in the instrument connection equipment. 5. Remove and clean the coarse and fine sieve, see Regular checks and cleaning [▶ page 68]. 6. Insert the non-return valve in the pump pit correctly, see Cleaning on demand [▶ page 70]. 7. Check for foreign bodies in the non-return valve.

Malfunction messages

Event	Possible cause	Remedy
137	The cleaning agent metering pump is not functioning correctly. The metering system may be blocked.	1. Switch the device off and then on again. 2. Start the program again.

Event	Possible cause	Remedy
139	The fan of the display is not functioning correctly.	<ol style="list-style-type: none"> 1. Switch the device off and then on again. 2. Start the program again.
140	The fan of the diffuser is not functioning correctly.	<ol style="list-style-type: none"> 1. Switch the device off and then on again. 2. Start the program again.
141	The neutralizer metering pump is not functioning correctly. The metering system may be blocked.	<ol style="list-style-type: none"> 1. Switch the device off and then on again. 2. Start the program again.
142	The rinse aid metering pump is not functioning correctly. The metering system may be blocked.	<ol style="list-style-type: none"> 1. Switch the device off and then on again. 2. Start the program again.
143	The solenoid valve for the cold water does not switch.	<ol style="list-style-type: none"> 1. Switch the device off and then on again. 2. Start the program again.
144	The solenoid valve for the regeneration does not switch.	<ol style="list-style-type: none"> 1. Switch the device off and then on again. 2. Start the program again.
145	The solenoid valve for the steam condenser does not switch.	<ol style="list-style-type: none"> 1. Switch the device off and then on again. 2. Start the program again.
146	The solenoid valve of the DI inflow hose does not switch.	<ol style="list-style-type: none"> 1. Switch the device off and then on again. 2. Start the program again.
147	The solenoid valve of the cold water inflow hose does not switch.	<ol style="list-style-type: none"> 1. Switch the device off and then on again. 2. Start the program again.
154 155	The temperature difference between the two temperature sensors (temperature control and temperature log) in the washing chamber is too high.	<ol style="list-style-type: none"> 1. Switch off the device and wait approx. 30 minutes with the door open. 2. Switch on the device and restart the program.
156	The temperature sensor for monitoring the drying is not functioning correctly.	<ol style="list-style-type: none"> 1. Switch off the device and wait approx. 30 minutes with the door open. 2. Switch on the device and restart the program.
159	The collection tank pump has not been emptied correctly.	<ol style="list-style-type: none"> 1. Switch the device off and then on again. 2. Start the program again.
160	The coarse or fine sieve is soiled.	<ol style="list-style-type: none"> 1. Switch off the device. 2. Clean the coarse and fine sieve, see Regular checks and cleaning [▶ page 68]. 3. Switch on the device and restart the program.
161	The washing chamber pressure required for drying has not been reached.	<ol style="list-style-type: none"> 1. Switch the device off and then on again. 2. Start the program again.
162	The requisite rinse pressure has not been reached.	<ol style="list-style-type: none"> 1. Switch the device off and then on again. 2. Start the program again.
163	The cleaning agent metering pump is not functioning correctly. The metering system may be blocked.	<ol style="list-style-type: none"> 1. Switch the device off and then on again. 2. Start the program again.
165	The fan of the display is not functioning correctly.	<ol style="list-style-type: none"> 1. Switch the device off and then on again. 2. Start the program again.
166	The fan of the diffuser is not functioning correctly.	<ol style="list-style-type: none"> 1. Switch the device off and then on again. 2. Start the program again.
167	The neutralizer metering pump is not functioning correctly. The metering system may be blocked.	<ol style="list-style-type: none"> 1. Switch the device off and then on again. 2. Start the program again.

Event	Possible cause	Remedy
168	The rinse aid metering pump is not functioning correctly. The metering system may be blocked.	<ol style="list-style-type: none"> 1. Switch the device off and then on again. 2. Start the program again.
169	The solenoid valve for the cold water does not switch.	<ol style="list-style-type: none"> 1. Switch the device off and then on again. 2. Start the program again.
171	The solenoid valve for the steam condenser does not switch.	<ol style="list-style-type: none"> 1. Switch the device off and then on again. 2. Start the program again.
172	The solenoid valve of the DI inflow hose does not switch.	<ol style="list-style-type: none"> 1. Switch the device off and then on again. 2. Start the program again.
173	The solenoid valve of the cold water inflow hose does not switch.	<ol style="list-style-type: none"> 1. Switch the device off and then on again. 2. Start the program again.
410	The rinse aid has been exhausted.	<ol style="list-style-type: none"> 1. Replace the rinse aid container, working in accordance with the working safety regulations. Alternatively, refill. NOTICE! Use only process agents which you have used before. 2. Start the "Air removal" program.
411	The neutralizer has been exhausted.	<ol style="list-style-type: none"> 1. Replace the neutralizer container, working in accordance with the working safety regulations. Alternatively, refill. NOTICE! Use only process agents which you have used before. 2. Start the "Air removal" program.
412	The cleaning agent has been exhausted.	<ol style="list-style-type: none"> 1. Replace the cleaning agent container, working in accordance with the working safety regulations. Alternatively, refill. NOTICE! Use only process agents which you have used before. 2. Start the "Air removal" program.
426	No cleaning agent is pumped. The cleaning agent container has been exhausted or air is being transported.	<ol style="list-style-type: none"> 1. Replace the cleaning agent container, working in accordance with the working safety regulations. Alternatively, refill. NOTICE! Use only process agents which you have used before. 2. Start the "Air removal" program.
	The hose to the suction lance is kinked.	<ol style="list-style-type: none"> 1. Rectify the kinks or crushing on the metering hoses. 2. Start the "Air removal" program.
	Air bubbles have developed in the metering system after long immobilization times.	Start the "Air removal" program.
431	No cleaning agent is pumped. The cleaning agent container has been exhausted or is nearly empty.	<ol style="list-style-type: none"> 1. Replace the cleaning agent container, working in accordance with the working safety regulations. Alternatively, refill. NOTICE! Use only process agents which you have used before. 2. Start the "Air removal" program.
	The hose to the suction lance is kinked.	<ol style="list-style-type: none"> 1. Rectify the kinks or crushing on the metering hoses. 2. Start the "Air removal" program.
	Air bubbles have developed in the metering system after long immobilization times.	Start the "Air removal" program.

Event	Possible cause	Remedy
432	No neutralizer is pumped. The neutralizer container has been exhausted or is nearly empty.	1. Replace the neutralizer container, working in accordance with the working safety regulations. Alternatively, refill. NOTICE! Use only process agents which you have used before. 2. Start the "Air removal" program.
	The hose to the suction lance is kinked.	1. Rectify the kinks or crushing on the metering hoses. 2. Start the "Air removal" program.
	Air bubbles have developed in the metering system after long immobilization times.	Start the "Air removal" program.
433	Water is in the pump pit after pumping out. The coarse or fine sieve is soiled.	Clean the coarse and fine sieve, see Regular checks and cleaning [▶ page 68].
	The non-return valve in the pump pit is missing or fitted incorrectly.	Insert the non-return valve in the pump pit correctly, see Regular checks and cleaning [▶ page 68].
	The non-return valve is blocked by a foreign body.	Check the non-return valve for foreign bodies and remove them if you find any.
434	Water is in the pump pit after pumping out. The coarse or fine sieve is soiled.	Clean the coarse and fine sieve, see Regular checks and cleaning [▶ page 68].
	The non-return valve in the pump pit is missing or fitted incorrectly.	Insert the non-return valve in the pump pit correctly, see Regular checks and cleaning [▶ page 68].
	The non-return valve is blocked by a foreign body.	Check the non-return valve for foreign bodies and remove them if you find any.
	The outlet hose is kinked.	Check the installation of the outlet hose.
	The outlet hose is blocked.	Check the siphon and the outlet hose for blockage.
440	The current program has been terminated prematurely. The load is classed as not cleaned and disinfected.	Acknowledge the message with the CONFIRM key.
449	The rinse pressure in the washing chamber is too low. The water inflow is insufficient.	Check the water inflow of the device. Open the water inflow tap completely.
	The basis basket has been inserted incorrectly or not at all.	Insert the basis basket in the washing chamber correctly, see Inserting the basis basket [▶ page 23].
	Too many non-filled apertures on the injector rail.	Seal non-filled apertures on the injector rail with a sealing screw.
	The coarse or fine sieve is soiled.	Remove and clean the coarse and fine sieve, see Regular checks and cleaning [▶ page 68].
	Large containers with the opening pointing upwards may have been sorted into the device. This diverts water from the rinsing process.	Sort the containers in the device with their openings facing downwards.
	Strong foam generation: the instruments have been pre-cleaned in or placed in a foam-generating solution and have then been subject to insufficient rinsing.	Rinse the instruments thoroughly before reprocessing.
	Strong foam generation: strong soiling of the filter disc in the universal adapter for transmission instruments.	Remove and replace the soiled filter disc. Clean the reusable filter screen.
Strong foam generation: unsuitable process agents (rinse aid or cleaning agent) have been used.	NOTICE! Use only those process agents suitable for this device.	

Event	Possible cause	Remedy
451	The temperature difference between the two temperature sensors in the washing chamber is too great. The temperature sensors were not covered with water sufficiently. The upper rinse arm revolves too slowly.	Clean the upper rinse arm and check its ease of movement.
462	The water inflow is insufficient.	Check the water inflow of the device.
464	The water inflow tap has not been opened completely.	Open the water inflow tap completely.
	The sieve in the cold water connection is blocked.	Remove and clean the sieve in the cold-water connection.
	The cold water inflow hose is kinked.	Check the installation of the cold water inflow hose.
466	Insufficient DI water inflow. The DI water supply has been interrupted.	Check the DI water supply. Check the DI water system for its correct function.
	The sieve in the DI water connection is blocked.	Remove and clean the sieve in the DI water connection.
	The DI water inflow hose is kinked.	Check the installation of the DI water inflow hose.
467	The water inflow is insufficient. The water inflow tap has not been opened completely.	Check the water inflow of the device. Open the water inflow tap completely.
	The sieve in the cold water connection is blocked.	Remove and clean the sieve in the cold-water connection.
	The cold water inflow hose is kinked.	Check the installation of the cold water inflow hose.
468	Insufficient DI water inflow. The DI water supply has been interrupted.	Check the DI water supply. Check the DI water system for its correct function.
	The sieve in the DI water connection is blocked.	Remove and clean the sieve in the DI water connection.
	The DI water inflow hose is kinked.	Check the installation of the DI water inflow hose.
471	The door of the device was not locked correctly during the program start.	Switch the device off and then on again.
474	The HEPA filter is not recognized. A HEPA filter has not been inserted.	Insert the HEPA filter.
	The HEPA filter for the drying fan has not been inserted correctly.	Check whether the HEPA filter for the drying fan has been inserted correctly.
	The lid of the drying fan has not been locked correctly.	Close the lid of the drying fan correctly.
476	The requisite pressure for the drying has not been achieved. The HEPA filter for the drying fan has not been inserted correctly.	Check whether the HEPA filter has been inserted correctly in the drying fan.
	The lid on the drying fan has not been locked correctly.	Close the lid of the drying fan correctly.

Event	Possible cause	Remedy
484	The rinse pressure in the washing chamber is too low. The water inflow is insufficient.	Check the water inflow of the device. Open the water inflow tap completely.
	The basis basket has been inserted incorrectly or not at all.	Insert the basis basket in the washing chamber correctly. The injector rail should be located on the right-hand side and dock with the blind cap on the port of the rear wall, see also Inserting the basis basket [▶ page 23].
	Too many non-filled apertures on the injector rail.	Seal non-filled apertures on the injector rail with a sealing screw.
	The coarse or fine sieve is soiled.	Remove and clean the coarse and fine sieve, see Regular checks and cleaning [▶ page 68].
	Large containers with the opening pointing upwards may have been sorted into the device. This diverts water from the rinsing process.	Sort the containers in the device with their openings facing downwards.
	Strong foam generation: the instruments have been pre-cleaned with a foam-generating solution and have then been subject to insufficient rinsing.	Rinse the instruments thoroughly before reprocessing.
	Strong foam generation: strong soiling of the filter disc in the universal adapter for transmission instruments.	Remove and replace the soiled filter disc. Clean the reusable filter screen.
	Strong foam generation: unsuitable process agents (rinse aid or cleaning agent) have been used.	NOTICE! Use only those process agents suitable for this device.
505	The salt storage has been exhausted. No new regeneration can be performed.	Fill regenerating salt, see Filling the regenerating salt [▶ page 24]. A program can be started if the salt has dissolved in the water. Do not start the program until the regenerating salt has been filled and the signal tone has sounded.
509	Liquid in the device floor trough.	CAUTION! Avoid contact with liquids in the floor trough; they can contain process agents. <ol style="list-style-type: none"> 1. Switch off the device. 2. Close the water inflow tap. 3. Contact the authorized customer services or stockist technician, stating the device serial number and the event number displayed.
510	Too high a water level was measured in the washing chamber during a program run.	<ol style="list-style-type: none"> 1. Working in the display, press the CONFIRM key. 2. Close the door and start the program again.
512	The running program was interrupted by a power cut.	WARNING! The load of the interrupted program has not been cleaned or disinfected. <ol style="list-style-type: none"> 1. Acknowledge the message with the CONFIRM key. 2. Start the program again.
524	The door of the device is blocked and cannot be closed correctly.	Check the door area for blockages.

Event	Possible cause	Remedy
531	The emergency release on the door was actuated during a program run.	WARNING! The load of the interrupted program has not been cleaned or disinfected. 1. Acknowledge the message with the CONFIRM key. 2. Close and lock the door correctly. 3. Start the program again.
535	The fine sieve has been fitted incorrectly.	Insert the fine sieve correctly. The arrow on the fine sieve must point towards the left-hand corner of the washing chamber.
536	The upper / lower rinse arm is mechanically blocked.	Check the freedom of motion of the upper / lower rinse arm.
537	The impulse nozzle of the upper / lower rinse arm is blocked.	Remove and clean the upper / lower rinse arm.
538		Insert the basis basket correctly. The injector rail must dock on to the connection fitting.
539		Remove and clean the upper / lower rinse arm. Clean the sliding disc with a cloth.
		Check the water inflow to the device: 1. Remove and clean the sieve in the cold water connection. 2. Check the installation of the inflow hose. 3. Open the water inflow tap completely.
546	The MELAdem 53 cartridge has not been bled correctly. A sudden water flow causes short-term incorrect measured values.	1. Bleed the MELAdem 53 cartridge of air, see the separate instructions "Hints for removing the air from the MELAdem 53/ MELAdem 53 C". 2. Start the program again.
548	The conductivity of the DI water is insufficient (greater than 60 $\mu\text{S}/\text{cm}$). The MELAdem 53 cartridge is exhausted.	Replace the MELAdem 53 cartridge.
	The DI water supply is of insufficient quality.	Check the DI water supply.
571	The program cannot be started as brine is still in the water softening unit or washing chamber. Only the "Regeneration" program may be started.	Start the "Regeneration" program.
583	The water inflow was interrupted during the active program.	1. Open the water inflow tap completely. 2. Start the program again. The water inflow must be secured during the entire duration of the active program.
620	Strong foam generation in the washing chamber. The instruments are pre-cleaned or placed in a foam-generating solution.	Load the instruments into the MELAtherm without pre-reprocessing or rinse them thoroughly after loading.
	Unsuitable process agents (rinse aid or cleaning agent) have been used.	NOTICE! Use only those process agents suitable for this device.
	The metering concentration has been set incorrectly.	Check the settings of the metering concentration and if necessary, arrange for correction by an authorized customer service or a stockist technician.
	Strong soiling of the filters in the transmission instrument adapter.	Clean or renew the filters in regular intervals.

Event	Possible cause	Remedy
624	The collection tank is not pumped out.	<ol style="list-style-type: none"> 1. Switch the device off and then on again. 2. Start the program again.
626	The temperature during pre-cleaning is too high.	Check the water supply to the device.
632	The coarse or fine sieve is soiled.	<ol style="list-style-type: none"> 1. Remove and clean the coarse and fine sieve, see Regular checks and cleaning [▶ page 68]. 2. Switch the device off and then on again. 3. Start the program again.
653	The water inflow was interrupted during the active program.	<ol style="list-style-type: none"> 1. Open the water inflow tap completely. 2. Start the program again. <p>The water inflow must be secured during the entire duration of the active program.</p>
660 661	The power supply for the <u>DTA</u> device version is insufficient.	<ol style="list-style-type: none"> 1. Check whether the power plug has been inserted correctly in the socket. 2. Check the fuses in the sub-distribution.
662	The upper rinse arm is soiled.	Remove the upper rinse arm and clean the nozzles, see Regular checks and cleaning [▶ page 68].
669	The coarse or fine sieve is strongly soiled.	<ol style="list-style-type: none"> 1. Remove and clean the coarse and fine sieve, see Regular checks and cleaning [▶ page 68]. 2. Switch the device off and then on again. 3. Start the program again.
670	The water inflow was interrupted during the active program.	<ol style="list-style-type: none"> 1. Open the water inflow tap completely. 2. Start the program again. <p>The water inflow must be secured during the entire duration of the active program.</p>
672	<p>Insufficient conductivity ($\geq 25 \mu\text{S}/\text{cm}$) was measured in the washing chamber during disinfection in the Ophthalmic-Program.</p> <p>This could be caused by carry-over of process agents, regenerating salt or deposits. The program successfully completed despite the warning.</p>	<ol style="list-style-type: none"> 1. Close the lid of the salt container correctly. 2. Setup the containers in the device with their openings facing downwards. 3. Check the hollow bodies before reprocessing for their free passage and correct position. 4. Clean the filter screen in the instrument connection equipment. 5. Remove and clean the coarse and fine sieve, see Regular checks and cleaning [▶ page 68]. 6. Insert the non-return valve in the pump pit correctly, see Cleaning on demand [▶ page 70]. 7. Check for foreign bodies in the non-return valve.
673	The Ophthalmic-Program does not start. A DI connection has not been set in the Settings menu.	<ol style="list-style-type: none"> 1. Connect the DI water. 2. Working in the display, select the Settings > DI water menu, and set the parameters to yes.

Event	Possible cause	Remedy
675	Water is in the pump pit after pumping out. The coarse or fine sieve is soiled.	Remove and clean the coarse and fine sieve, see Regular checks and cleaning [▶ page 68].
	The non-return valve in the pump pit is missing or has been fitted incorrectly.	Insert the non-return valve in the pump pit correctly.
	The non-return valve is blocked by foreign bodies.	Check whether foreign bodies are in the non-return valve, see Cleaning on demand [▶ page 70].

13 Technical data

MELAtherm 10 Evolution DTA/DTB device dimensions

Device type	Semi-integrated unit	Free standing	Top-frame device
Device dimensions (H x W x D) ³⁾	81.8 x 59.8 x 68.1 cm	83.6 x 59.8 x 68.1 cm	124 x 59.8 x 68.1 cm
Empty weight	88 kg	94 kg	115 kg
Operating weight	122 kg	128 kg	191 kg

Device type	MELAtherm 10 Evolution DTA	MELAtherm 10 Evolution DTB
Washing chamber (H x W x D)	29 x 45.5 x 42.3 cm	
Volume of the washing chamber	84 l	
Electrical connection		
Power supply	3N AC 380-415 V, 50 Hz	AC 220-240 V, 50 Hz
Max. voltage range	360-440 V	207-253 V
Electrical power	10.3 kW	3.4 kW
Building fuses	3x 16 A, separate power circuit with Type B 16 A fuse, RCD switch with 30 mA	1x 16 A, separate power circuit with Type B 16 A fuse, RCD switch with 30 mA
Overvoltage category	Transient overvoltage up to the values of overvoltage category II	
Length of the power cable	2 m	
Degree of air pollution (in accordance with DIN EN 61010-1)	Category 2	
Ambient conditions		
Installation location	Interior of a building	
Max. noise emission (Drying)	73 dB(A)	
Noise emission median value	66.2 dB(A)	
Waste heat (with max. solid load)	0.98 kWh (3.5 MJ)	
Ambient temperature	5-40 °C (recommended max. 25 °C)	
Air pressure	75-106 kPa (750-1060 mbar)	
Relative humidity	max. 80 % at temperatures up to 31 °C, max. 50 % at 40 °C (decreasing in a linear fashion)	
Degree of protection (following IEC 60529)	IP20	
Max. altitude	1500 m (it may be necessary to reduce the disinfection temperature depending on the installation height; consult the technical manual)	
Cold water		
Connection CW / DI water	3/4" internal thread (for the connection to a standard 3/4" connection with external thread)	
Cold water quality	Comply with the specifications of the Drinking Water Ordinance (TrinkwV) or the applicable local specifications	
DI water quality (max. permissible conductivity)	from 15 µS/cm warning, from 60 µS/cm malfunction	
Min. flow pressure	150 kPa (1.5 bar) Netherlands: 200 kPa (2 bar)	
Recommended flow pressure	250 kPa (2.5 bar) Netherlands: 300 kPa (3 bar)	
Max. water pressure (static)	1000 kPa (10 bar)	
Cold water temperature	1-26 °C	

³⁾ Appropriate for a 60 cm deep working surface

Device type	MELAtherm 10 Evolution DTA	MELAtherm 10 Evolution DTB
Wastewater		
Wastewater connection	DN21	
Max. wastewater temperature	93 °C (< 1 min, approx. 7 l)	
Amount of wastewater per hour	approx. 38 l (in short intervals)	
Capacity of drain pump	max. 40 l/min (volume in wastewater hose)	
Length of the inflow hose and outlet hose	each 1.80 m (extension optionally available)	

14 Accessories and spare parts

You can obtain the specified articles together with an overview of further accessories from your stockist. Information regarding the instrument reprocessing accessories can be found in the current MELAG price list.

	Article	Art. no.
Optionally available	Floor unit (H x W x D) 40 cm x 59.8 cm x 59.8 cm	11021
	Stainless steel cover plate (H x W x D) 1.8 cm x 59.8 cm x 59.8 cm	65310
Water treatment	MELAdem 53	01038
	MELAdem 53 C	01036
For documentation	MELAflash CF card	01043
	MELAflash card reader	01048
	MELAprint 44 log printer	01144
	Ethernet adapter for MELAprint 42/44	40295
Process agents	1 l container for rinse aid	60910
Others	Pre-filter	68130
	HEPA filter	51240
	Feed funnel	68200
	Container tap for a 5 litre and 10 litre container	70100

15 Documentation and approval

			Program/ load	Process successful?	Process approval?	Approval instruments?	Remarks	Signature
				<input type="checkbox"/> yes <input type="checkbox"/> no	<input type="checkbox"/> yes <input type="checkbox"/> no	<input type="checkbox"/> yes <input type="checkbox"/> no <input type="checkbox"/> partially		
				<input type="checkbox"/> yes <input type="checkbox"/> no	<input type="checkbox"/> yes <input type="checkbox"/> no	<input type="checkbox"/> yes <input type="checkbox"/> no <input type="checkbox"/> partially		
				<input type="checkbox"/> yes <input type="checkbox"/> no	<input type="checkbox"/> yes <input type="checkbox"/> no	<input type="checkbox"/> yes <input type="checkbox"/> no <input type="checkbox"/> partially		
				<input type="checkbox"/> yes <input type="checkbox"/> no	<input type="checkbox"/> yes <input type="checkbox"/> no	<input type="checkbox"/> yes <input type="checkbox"/> no <input type="checkbox"/> partially		
				<input type="checkbox"/> yes <input type="checkbox"/> no	<input type="checkbox"/> yes <input type="checkbox"/> no	<input type="checkbox"/> yes <input type="checkbox"/> no <input type="checkbox"/> partially		
				<input type="checkbox"/> yes <input type="checkbox"/> no	<input type="checkbox"/> yes <input type="checkbox"/> no	<input type="checkbox"/> yes <input type="checkbox"/> no <input type="checkbox"/> partially		
				<input type="checkbox"/> yes <input type="checkbox"/> no	<input type="checkbox"/> yes <input type="checkbox"/> no	<input type="checkbox"/> yes <input type="checkbox"/> no <input type="checkbox"/> partially		
				<input type="checkbox"/> yes <input type="checkbox"/> no	<input type="checkbox"/> yes <input type="checkbox"/> no	<input type="checkbox"/> yes <input type="checkbox"/> no <input type="checkbox"/> partially		
				<input type="checkbox"/> yes <input type="checkbox"/> no	<input type="checkbox"/> yes <input type="checkbox"/> no	<input type="checkbox"/> yes <input type="checkbox"/> no <input type="checkbox"/> partially		
				<input type="checkbox"/> yes <input type="checkbox"/> no	<input type="checkbox"/> yes <input type="checkbox"/> no	<input type="checkbox"/> yes <input type="checkbox"/> no <input type="checkbox"/> partially		

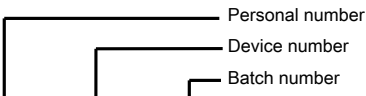

Glossary

A0-value

The A0 value represents a standard for the elimination of microorganisms and the deactivation of viruses in the disinfection procedure with damp heat. The A0 value depends on temperature and time.

AKI

Abbr.: working group instrument preparation ("Arbeitskreis Instrumentenaufbereitung")

Authorized technician

The term "authorized technician" refers to an employee of a customer service provider or stockist who has been trained and authorized by MELAG to perform maintenance and installation work on MELAG devices. Only they may carry out this work.

Batch

The batch is the composition of items which has been subject to the same decontamination procedure.

Cleaning agent

A cleaning agent is a substance or mixture of chemical substances which supports the cleaning of medical devices.

Conductivity

Conductivity refers to the ability of a conductive chemical material or mixture to conduct or transfer other materials or particles.

DI water

Demineralized water (DI water) is water (H₂O) which does not contain any of the minerals (salts and ions) dissolved in normal spring or tap water as anions and cations.

Empty batch

Program run without a load or accessories (only with a basis basket).

HEPA filter

The HEPA filter is a filter group H filter element (particulate material filter), in accordance with EN 1822-1. This group is sub-divided into two classes, H13 and H14. Filter elements are classified in accordance with their filter capacity. The HEPA filter is used in medical environments to purify the air microbiologically from suspended particles.

Load

The load refers to all possible instruments such as basins, glassware and other objects which can be reprocessed in a washer-disinfector.

Neutralizer

The neutralizer is a citric acid-based (e.g. MEtherm 55) or phosphoric acid-based (e.g. MEtherm 56) acidic medium which can be added to the subsequent rinse water in automatic reprocessing after an alkaline cleaning in order to neutralize the alkalinity in order to assist in the removal of the cleaning agent.

pH Value

The pH value is a measure of the strength of the acid or alkali effect of a watery solution.

Process agents

A process agent is a composition of chemical compounds for designed for reprocessing purposes e.g. of medical instruments. Process agents used in a washer-disinfector consist of a cleaning agent, neutralizer and rinse aid.

Rinse aid

The rinse aid is a mixture of chemical substances which can be added to the last subsequent rinse water used in an automatic reprocessing process to achieve better and quicker drying. The active agents contained in the subsequent rinse medium reduce the surface tension of the subsequent rinse water, thereby minimizing the adherent residual moisture.

MELAG Medizintechnik oHG

Geneststraße 6-10
10829 Berlin
Germany

Email: info@melag.com
Web: www.melag.com

Original instructions

Responsible for content: MELAG Medizintechnik oHG
We reserve the right to technical alterations

Your stockist
